

Accelerator Physics

Lecture 8

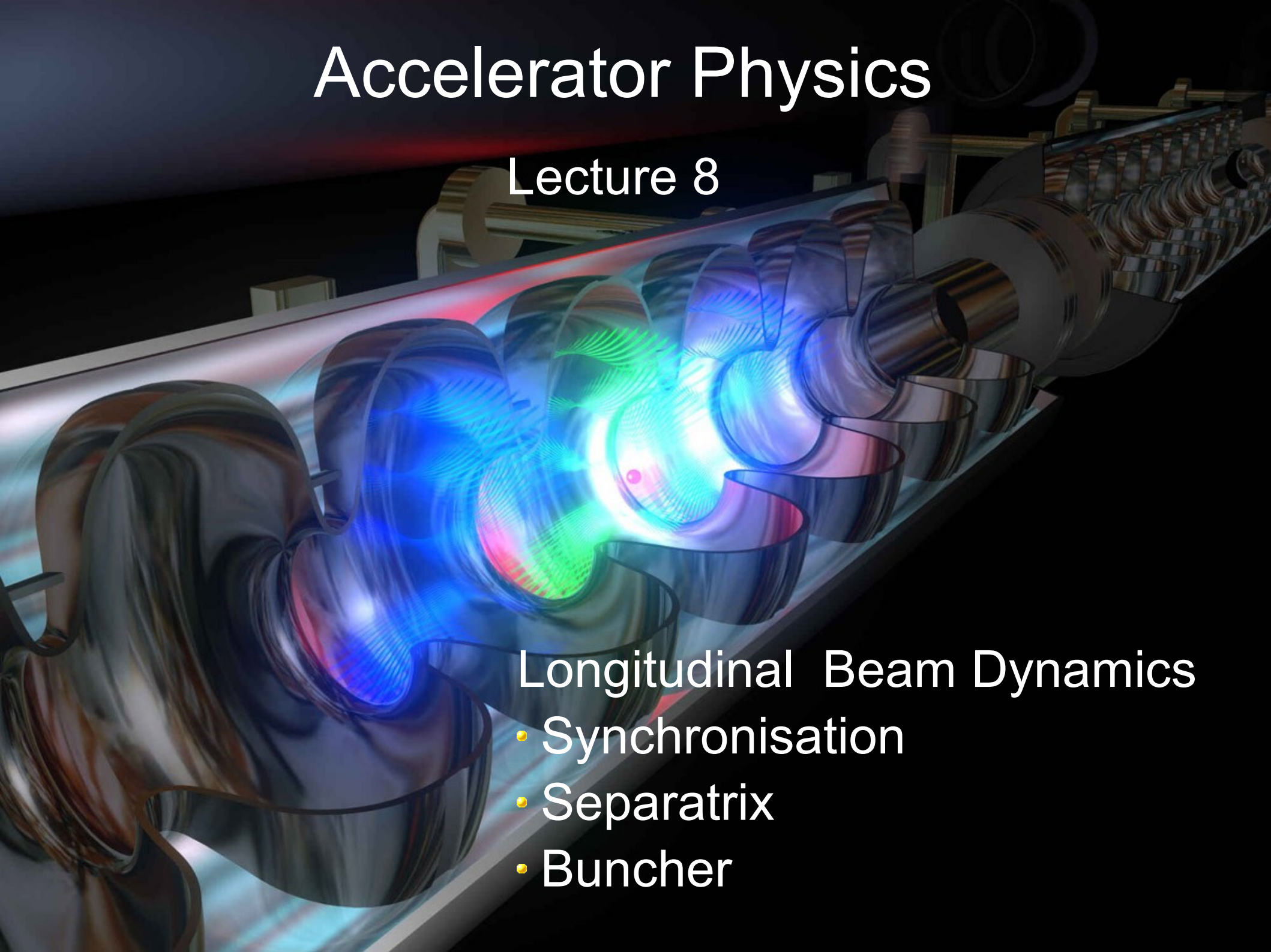

Longitudinal Beam Dynamics

- Synchronisation
- Separatrix
- Buncher

Stable Region of HF-Acceleration

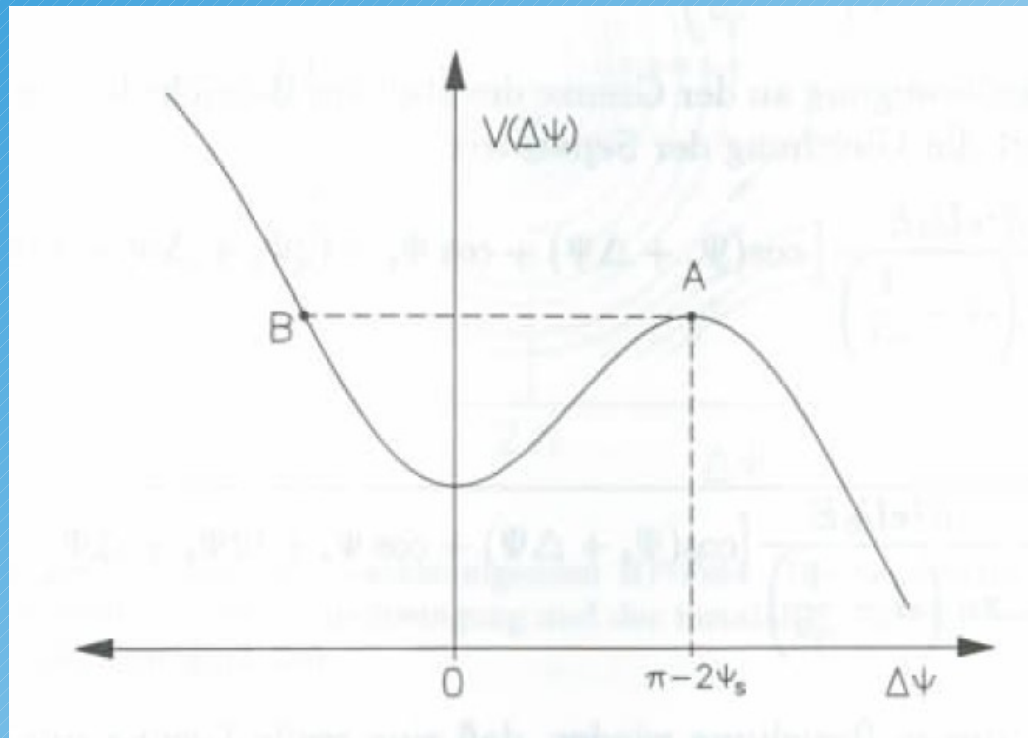

Separatrix and Nominal Phase

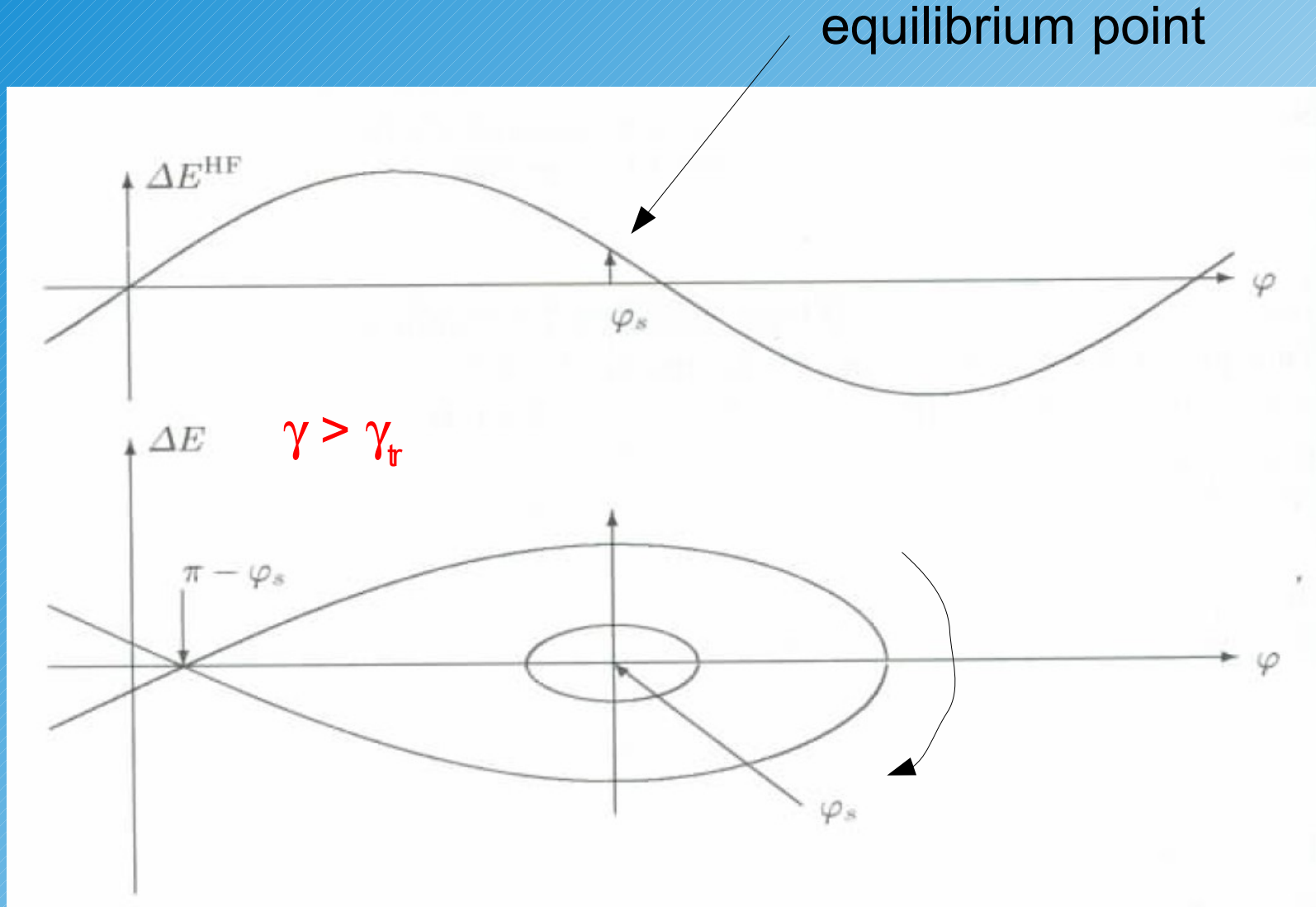

Separatrix and Nominal Phase

equilibrium point

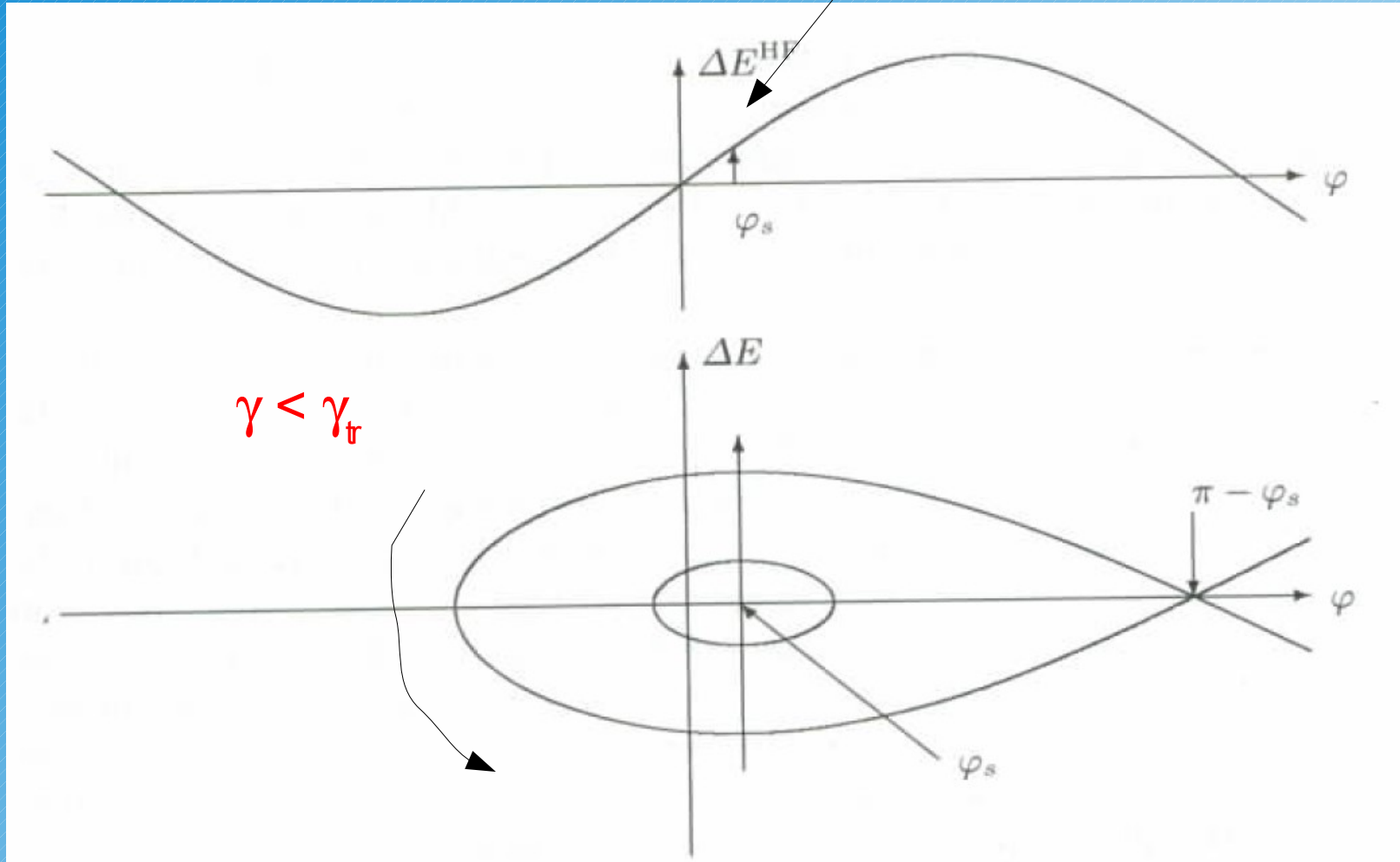

Bucket Structures

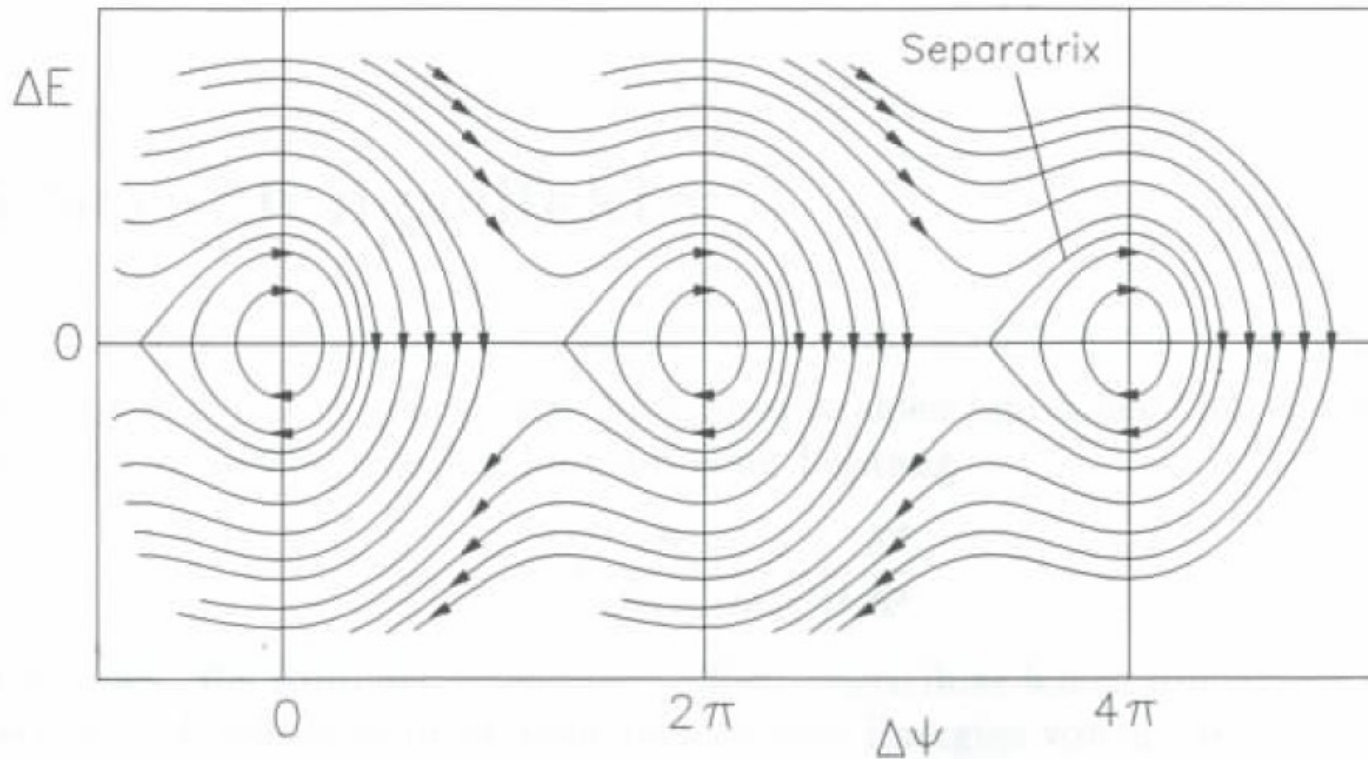
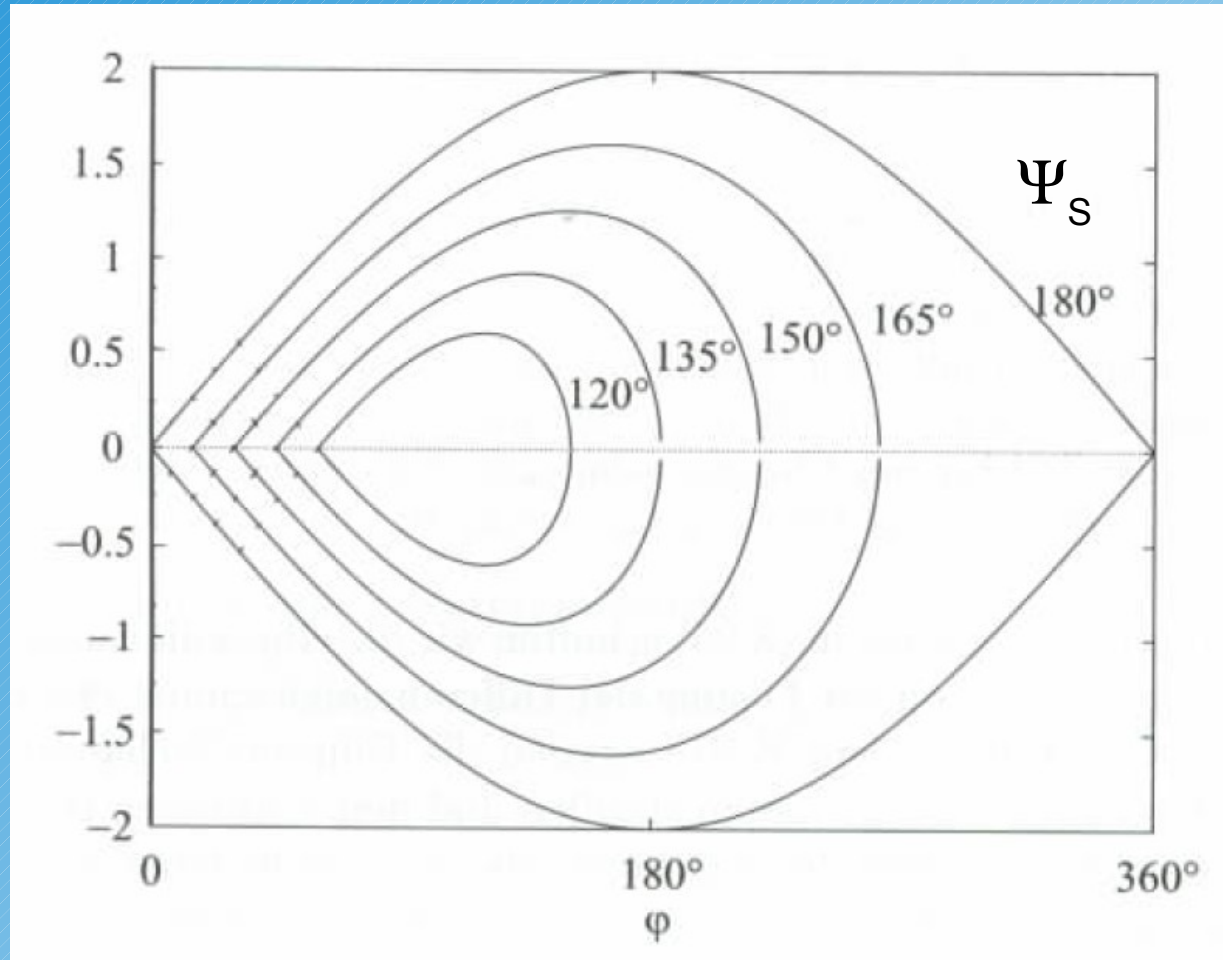

Fig. 5.17 Teilchenbewegung im beschleunigenden HF-Feld. Die Separatrix legt die Grenze zwischen der stabilen Synchrotronschwingung und der instabilen, für die Beschleunigung ungeeigneten Teilchenbewegung fest.

Bucket and Separatrix

$$\Delta E \sim \dot{\Psi} / \omega_{sn}$$



FODO element

FODO element

Buncher

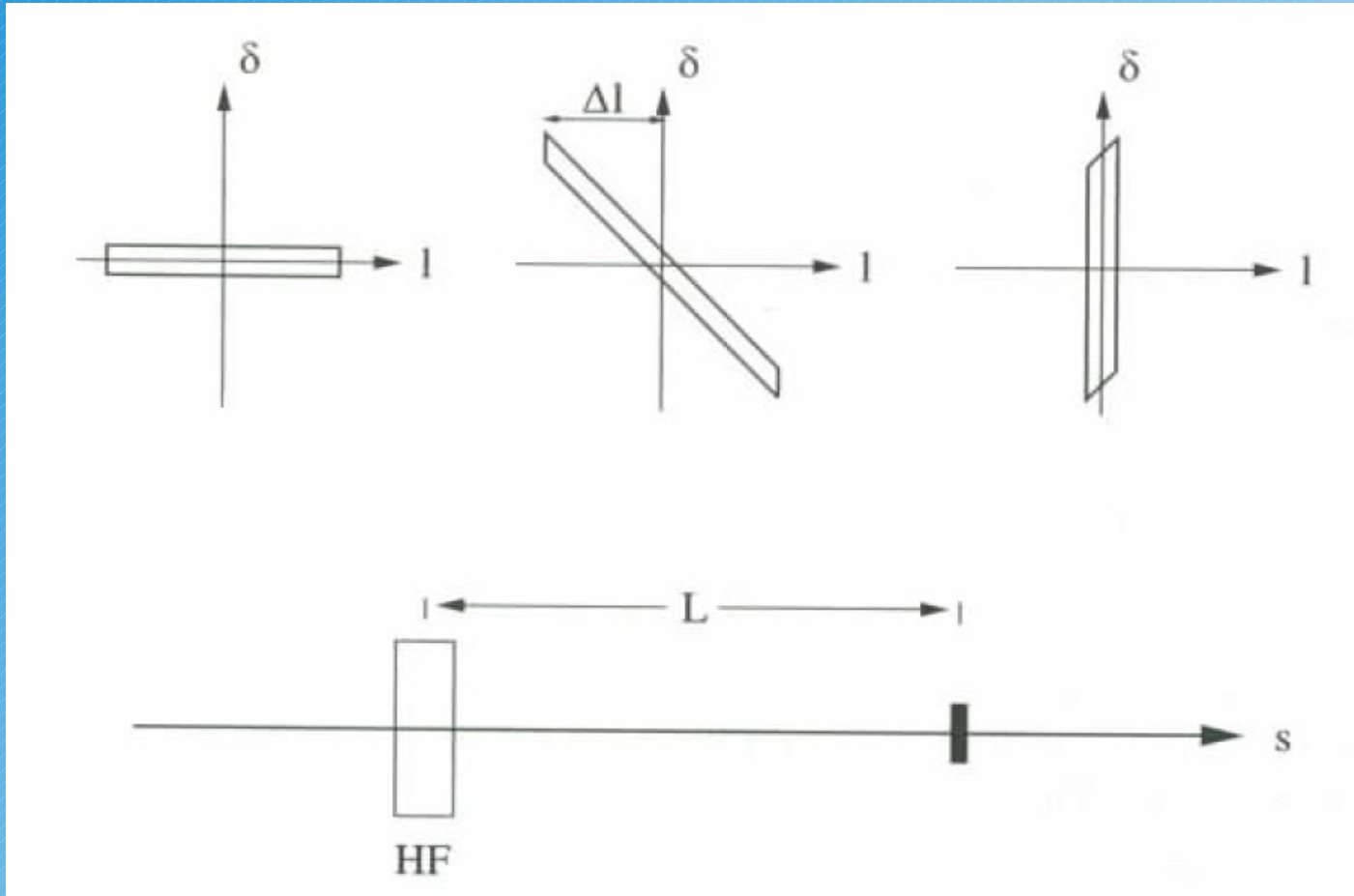

Visit of ANKA in Karlsruhe (KIT)

Proposed Dates (Monday Mornings)

10.01.

17.01.

24.01.

