



Bundesministerium  
für Bildung  
und Forschung

# High Spatial Resolution in thermal Neutron Detection: from CASCADE to BASTARD



*DPG Frühjahrstagung Münster*  
27.03.2017



Physikalisches Institut (LCTPC)  
Rheinische  
Friedrich-Wilhelms-Universität  
Bonn

universität**bonn**

**Markus Köhli**

M. Klein, U. Schmidt (Uni Heidelberg)  
T. Wagner, F. Schmidt, J. Kaminski, K. Desch (Uni Bonn)

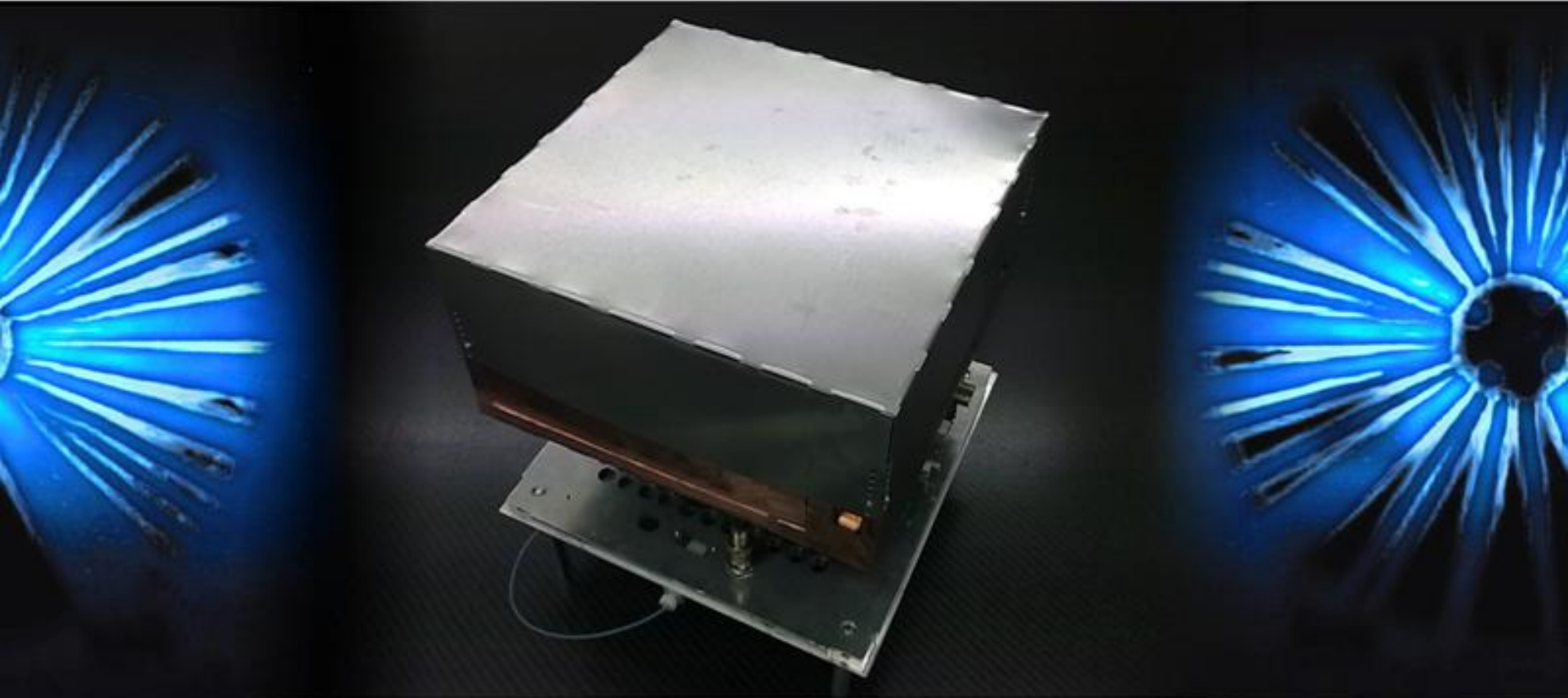

# Neutron Capture

Element	Reaction	CS at 25.2 meV
$^3\text{He}$	$^3\text{He} + n \rightarrow ^3\text{H} + 764 \text{ keV}$	5327 b
$^6\text{Li}$	$^6\text{Li} + n \rightarrow ^3\text{H} + \alpha + 4.78 \text{ MeV}$	940 b
$^{10}\text{B}$	$^{10}\text{B} + n \rightarrow ^7\text{Li} + \alpha + 2.79 \text{ MeV} (6.4\%)$	3837 b
	$^{10}\text{B} + n \rightarrow ^7\text{Li} + \gamma + \alpha + 2.31 \text{ MeV} (93.6\%)$	

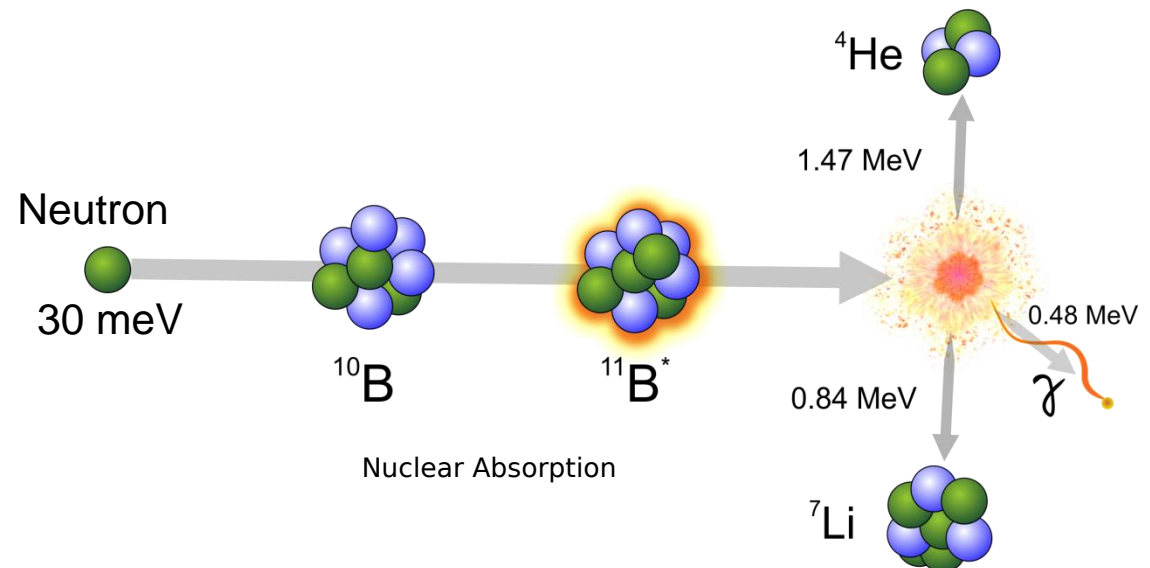

# The Helium-3 Crisis

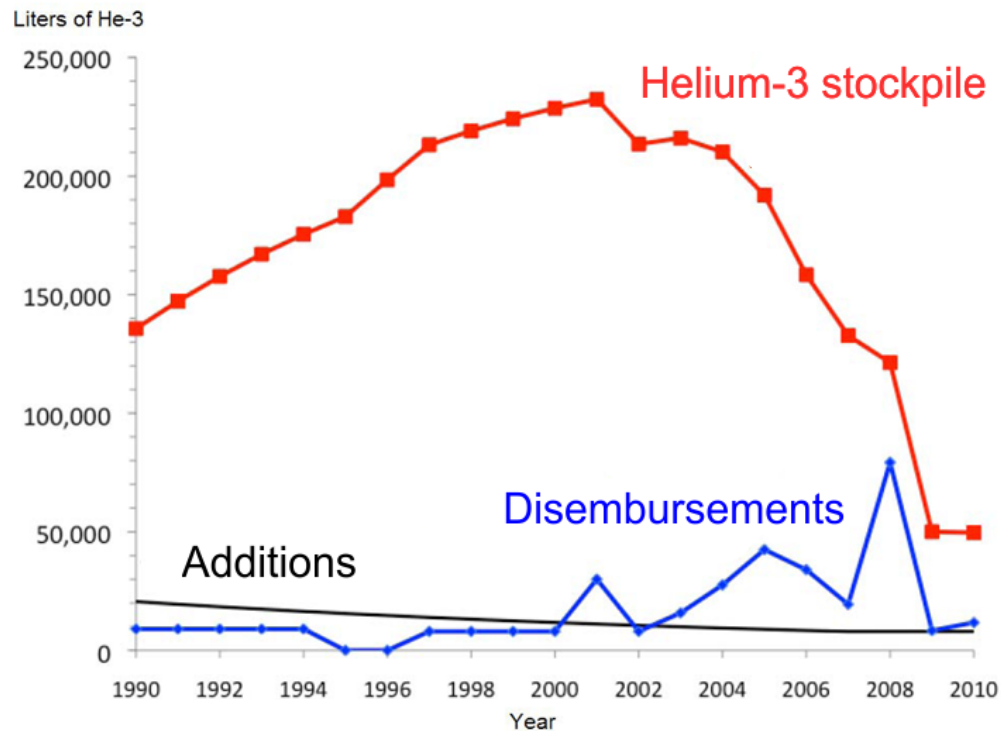

AAAS, Overview of Helium-3 Supply and Demand

# The Helium-3 Crisis

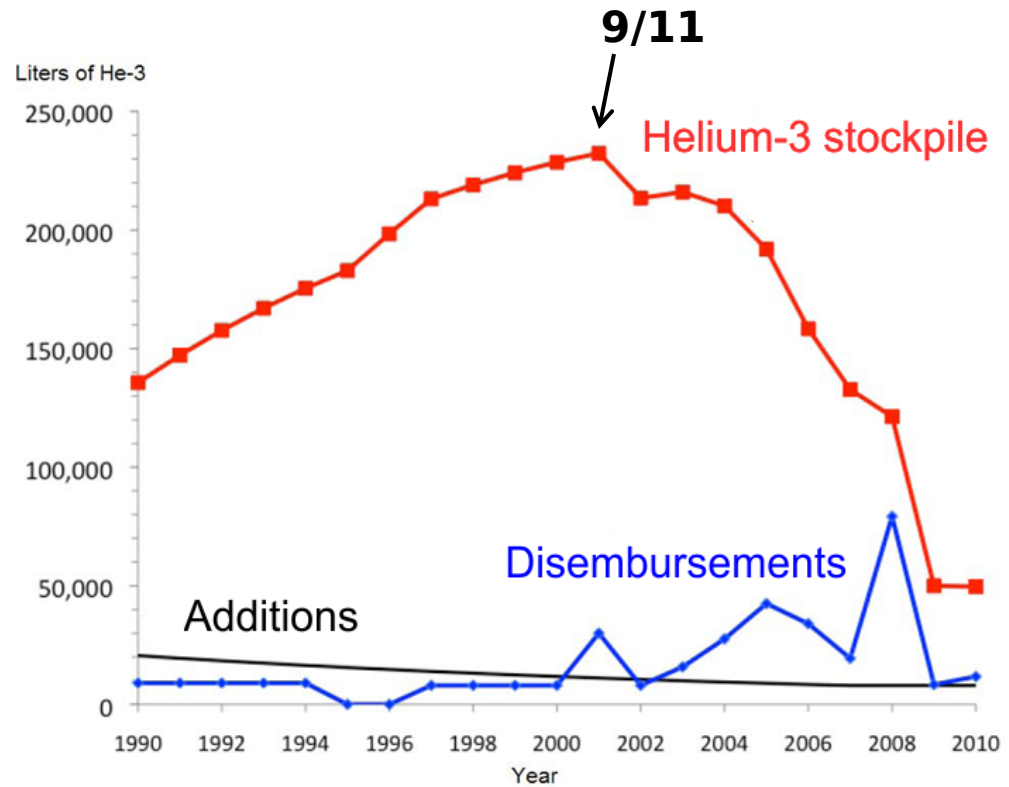

AAAS, Overview of Helium-3 Supply and Demand



[1]



[2]

[1] <http://www.saphymo.com/photos/ecatalogue/116-2/access-control-clearance-monitors-rcp-radiological-control-for-pedestrian.jpg>  
 [2] [http://cits.uga.edu/uploads/1540compass/1540images/\\_compass750/RPM1.jpg](http://cits.uga.edu/uploads/1540compass/1540images/_compass750/RPM1.jpg)

# The European Spallation Source



ESS TDR 2013  
Lund, Sweden

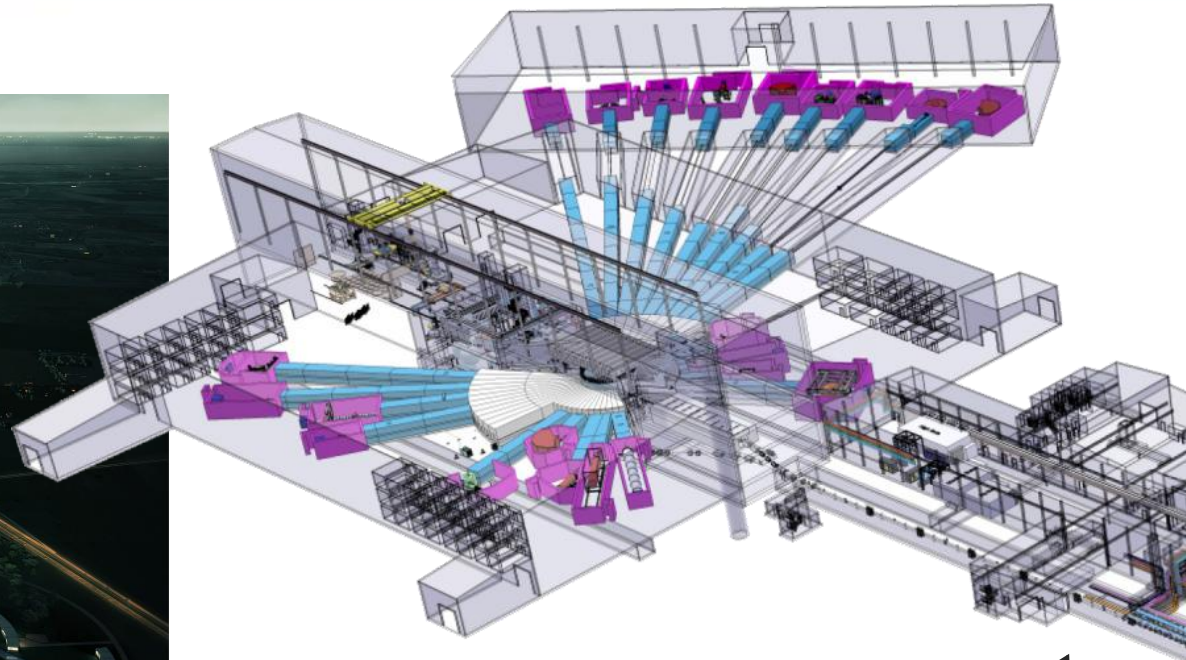

Linear Accelerator  
2 GeV  
3 ms Pulse  
62.5 mA

# ESS Instrumentation

Instrument	Detector area [m <sup>2</sup> ]	Wavelength range [Å]	Time resolution [μs]	Spatial resolution [mm]
Multi-purpose imaging	0.5	1 - 20	1	0.001 - 0.5
General purpose polarised SANS	5	4 - 20	100	10
Broad-band small sample SANS	14	2 - 20	100	1
Surface scattering	5	4 - 20	100	10
Horizontal reflectometer	0.5	5 - 30	100	1
Vertical reflectometer	0.5	5 - 30	100	1
Thermal powder diffractometer	20	0.6 - 6	< 10	2 × 2
Bi-spectral powder diffractometer	20	0.8 - 10	< 10	2.5 × 2.5
Pulsed monochromatic powder diffractom.	4	0.6 - 5	< 100	2 × 5
Material science & engineering diffractom.	10	0.5 - 5	10	2
Extreme conditions instrument	10	1 - 10	< 10	3 × 5
Single crystal magnetism diffractometer	6	0.8 - 10	100	2.5 × 2.5
Macromolecular diffractometer	1	1.5 - 3.3	1000	0.2
Cold chopper spectrometer	80	1 - 20	10	
Bi-spectral chopper spectrometer	50	0.8 - 20	10	
Thermal chopper spectrometer	50	0.6 - 4	10	
Cold crystal-analyser spectrometer	1	2 - 8	< 10	
Vibrational spectroscopy	1	0.4 - 5	< 10	
Backscattering spectrometer	0.3	2 - 8	<	
High-resolution spin echo	0.3	4 - 25	100	10
Wide-angle spin echo	3	2 - 15	100	10
Fundamental & particle physics	0.5	5 - 30	1	0.1
<b>Total</b>	<b>282.6</b>			

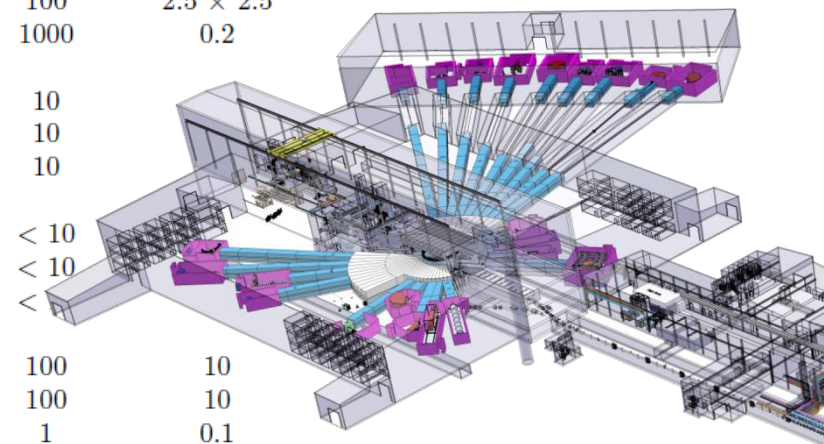

ESS TDR 2013

# ESS Instrumentation

Instrument	<sup>10</sup> B thin films		Detector technology			Micropattern	
	⊥	∥	WSF	Anger	<sup>3</sup> He	Rate	Resolution
Multi-purpose imaging	-	-	-	-	-	0	+
General purpose polarised SANS	0	+	-	+	0	+	-
Broad-band small-sample SANS	0	+	-	+	-	+	-
Surface scattering	0	+	-	+	0	+	-
Horizontal reflectometer	-	0	-	+	+	0	-
Vertical reflectometer	-	0	-	+	+	0	-
Thermal powder diffractometer	0	+	+	-	-	0	-
Bi-spectral powder diffractometer	0	+	+	-	-	0	-
P-M powder diffractometer	0	+	+	-	-	0	-
MS engineering diffractometer	0	+	+	-	-	0	-
Extreme conditions diffractometer	0	+	+	-	-	0	-
Single crystal diffractometer	0	+	+	-	-	0	-
Macromolecular diffractometer	-	0	0	0	-	+	+
Cold chopper spectrometer	+	0	0	-	-	-	-
Bi-spectral chopper spectrometer	+	+	0	-	-	-	-
Thermal chopper spectrometer	+	+	+	-	-	-	-
Cold crystal analyser spectrometer	-	0	-	+	+	-	-
Vibrational spectrometer	-	0	-	0	+	-	-
Backscattering spectrometer	-	0	-	+	+	-	-
High-resolution spin echo	-	0	-	0	+	+	-
Wide-angle spin echo	-	0	-	0	+	+	-
Fundamental & particle physics	-	-	-	-	+	+	+

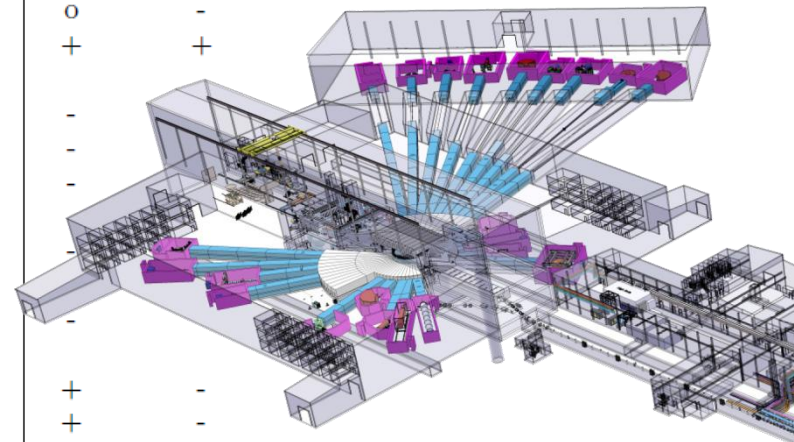

ESS TDR 2013

# ||| CASCADE The Detector

Heidelberg University





# ▶ The CASCADE Detector

CASCADE detector without housing

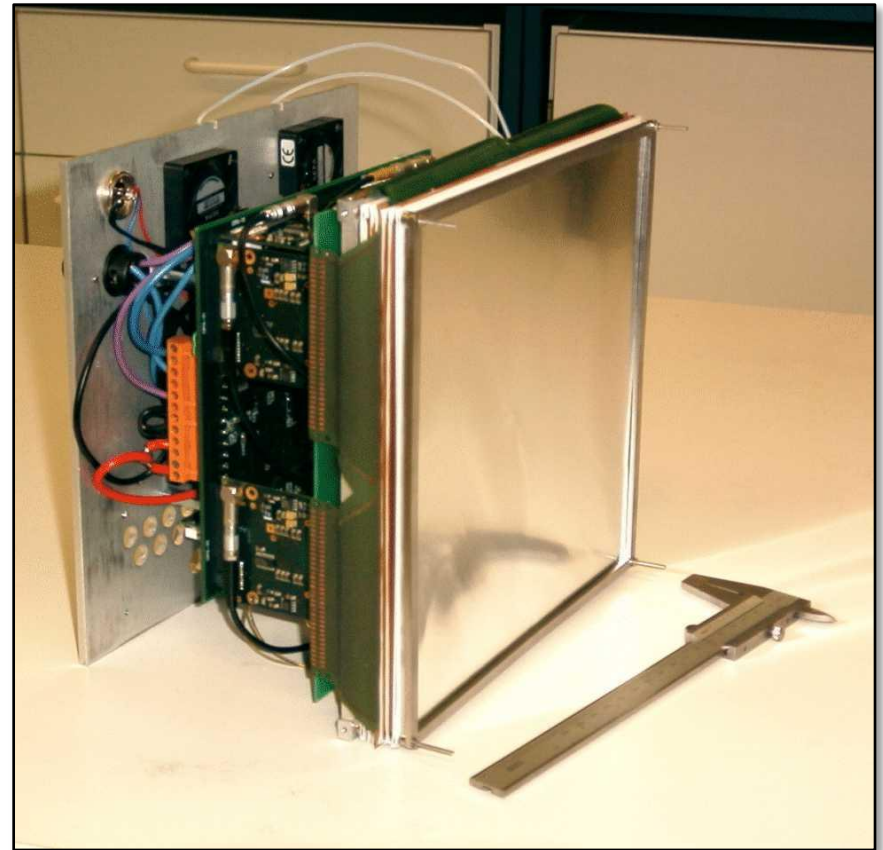

# The CASCADE Detector

## Active Detection Volume

6 layers of Boron-10

## Readout

128x128 crossed stripes @ 1.56 mm

## Electronics

5x CIPix 64ch @ FPGA 10 MHz

## DAQ

Firmware based event reconstruction

CASCADE detector without housing

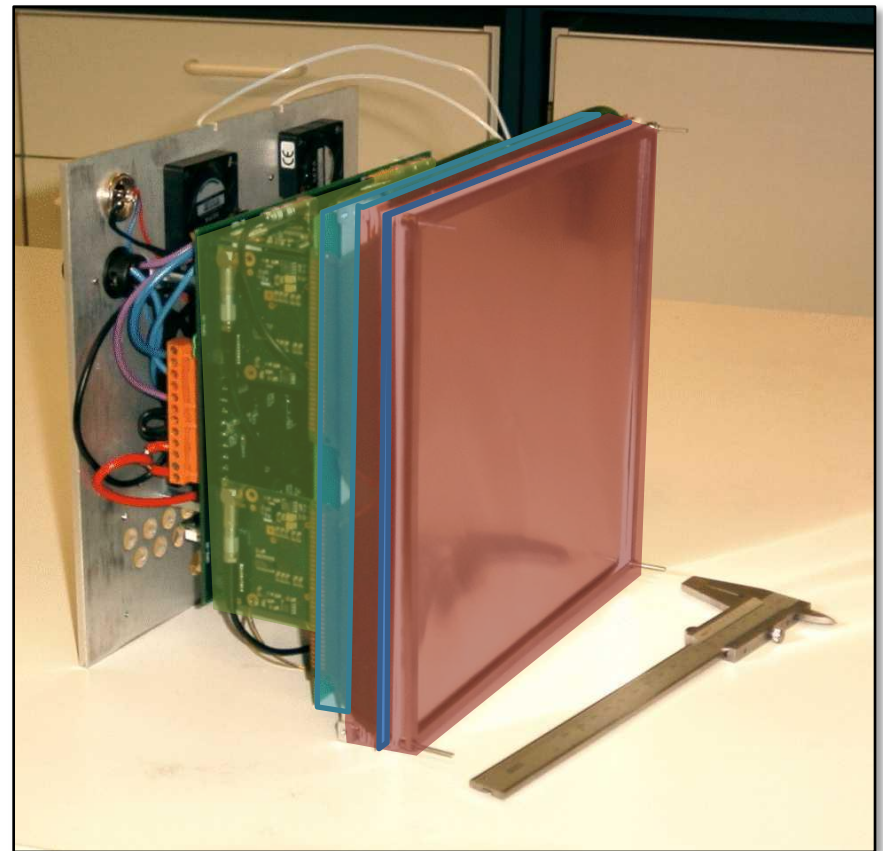

# The CASCADE Concept

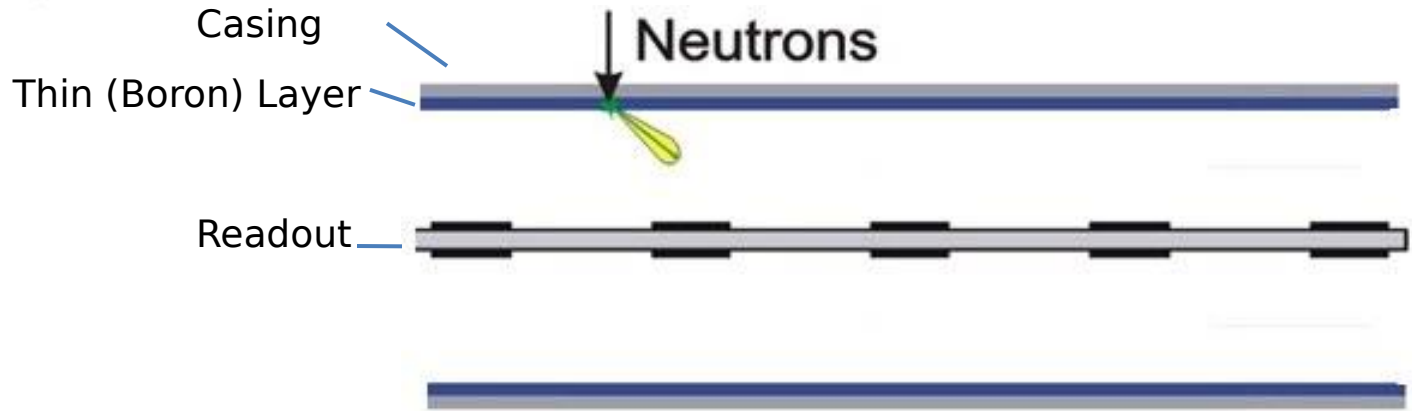

# The CASCADE Concept

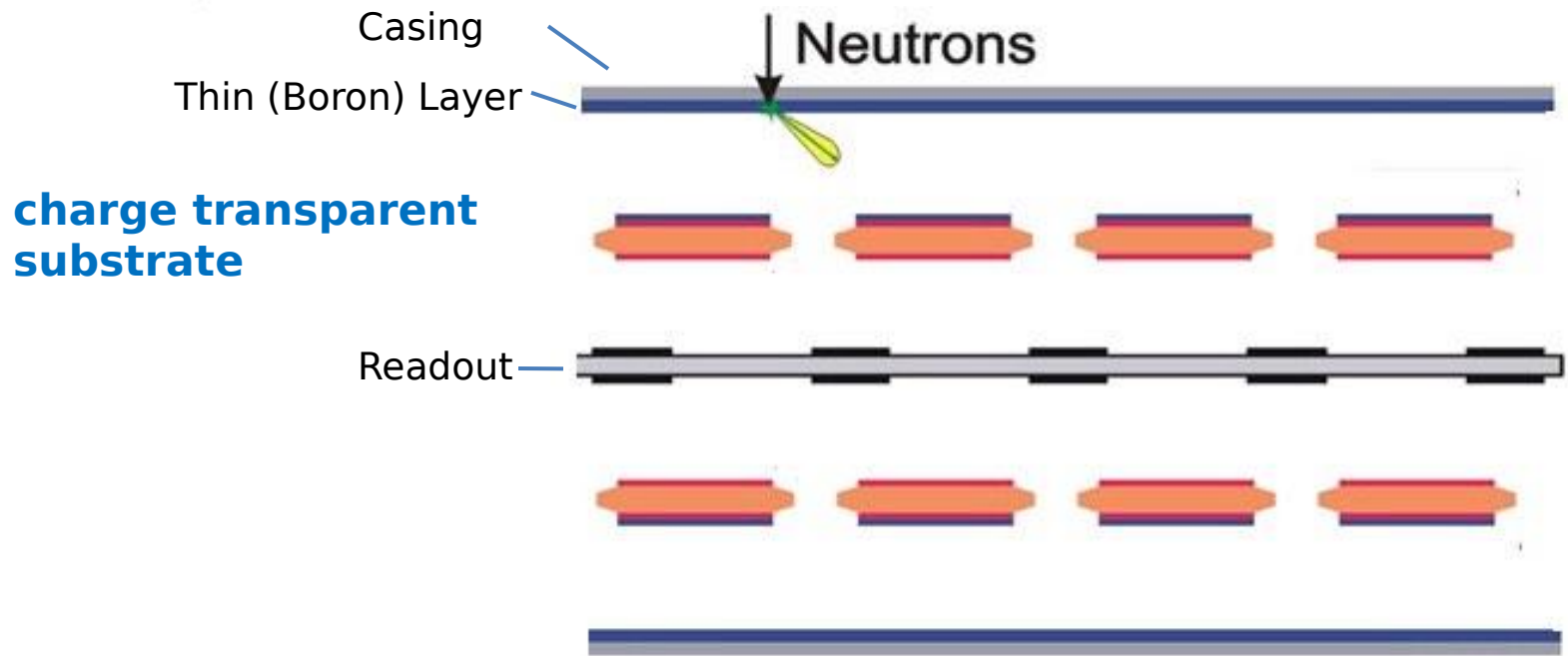

# The CASCADE Concept

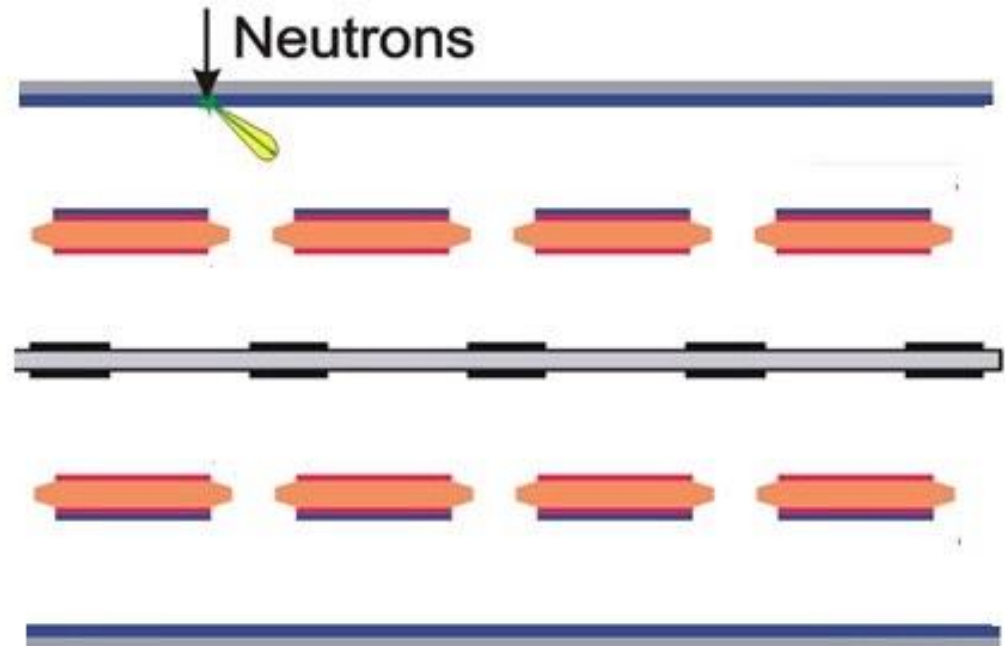
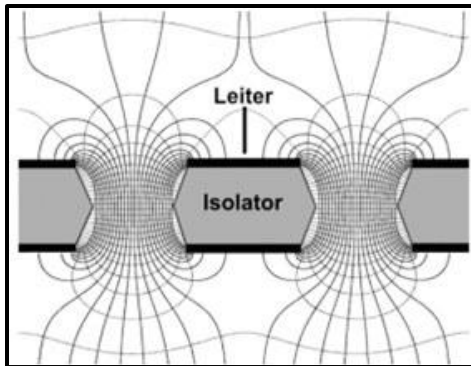
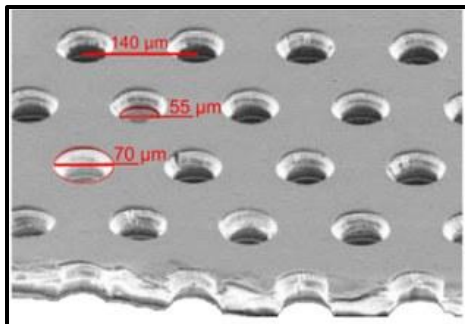

**GEM**  
(Gas Electron Multiplier foil)

# The CASCADE Concept

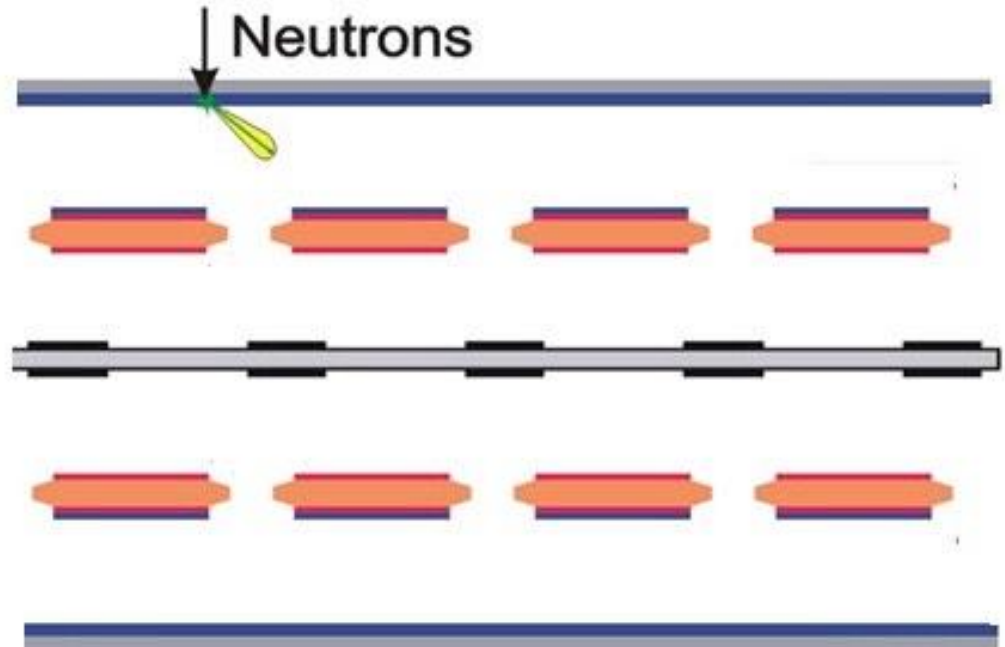
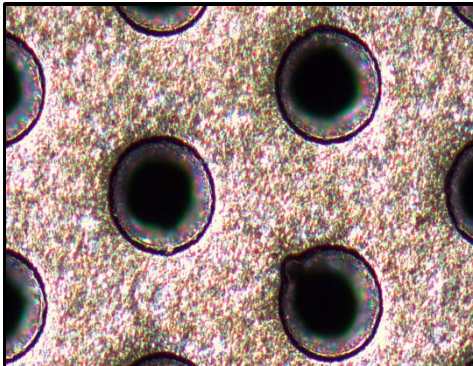
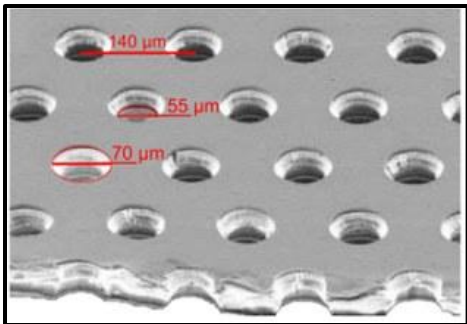

**GEM**  
(Gas Electron Multiplier foil)

# The CASCADE Concept

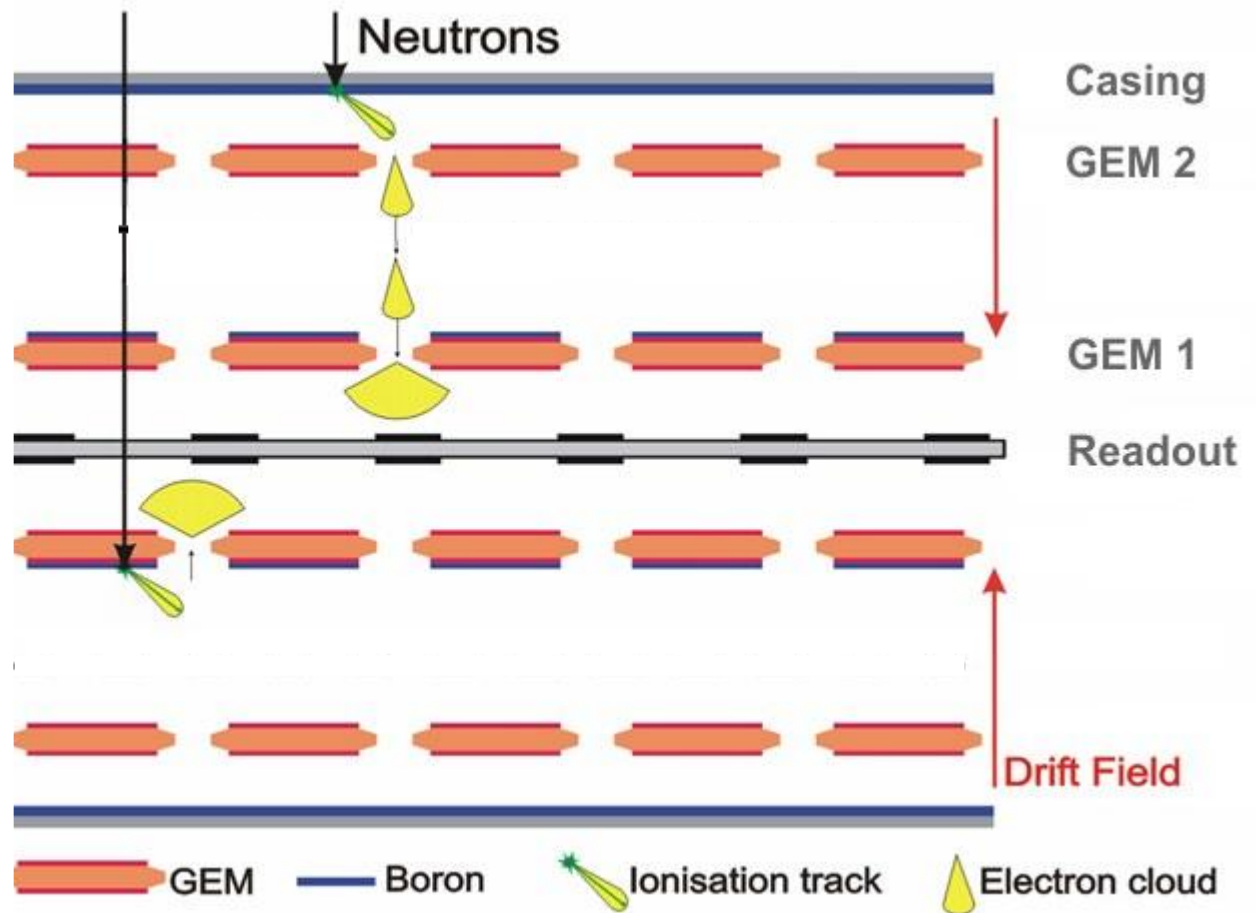

# The CASCADE Concept

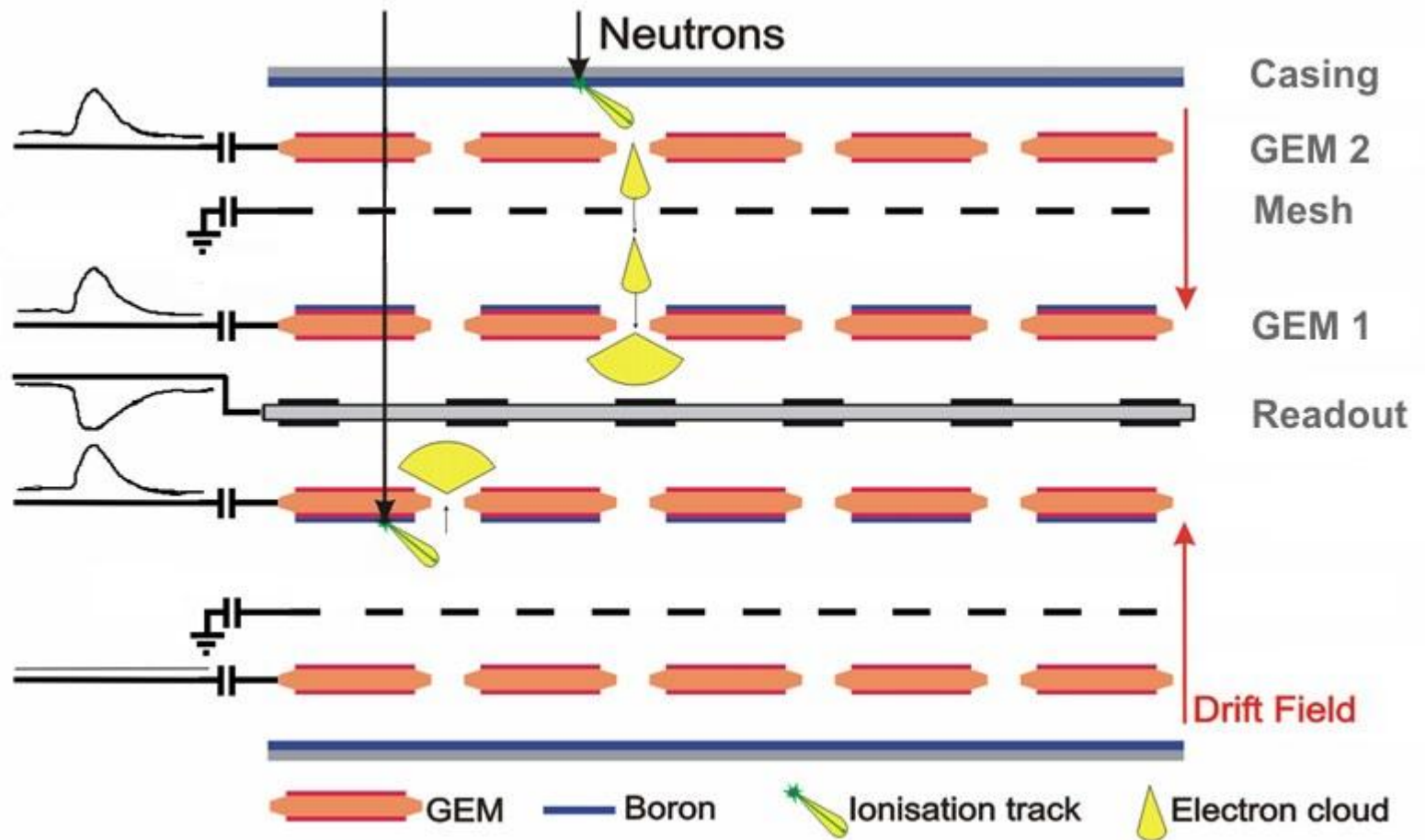



# Spatial Resolution

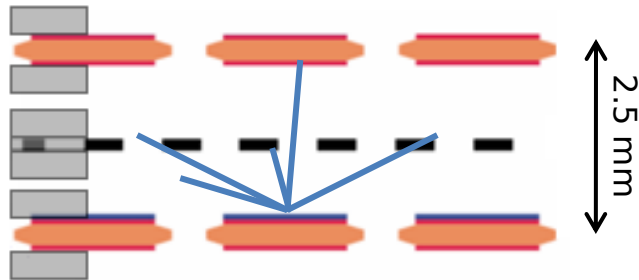

Spatial resolution: 2.4 mm FWHM

Image of a cold neutron beam (after guide)

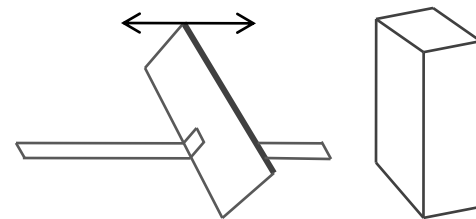
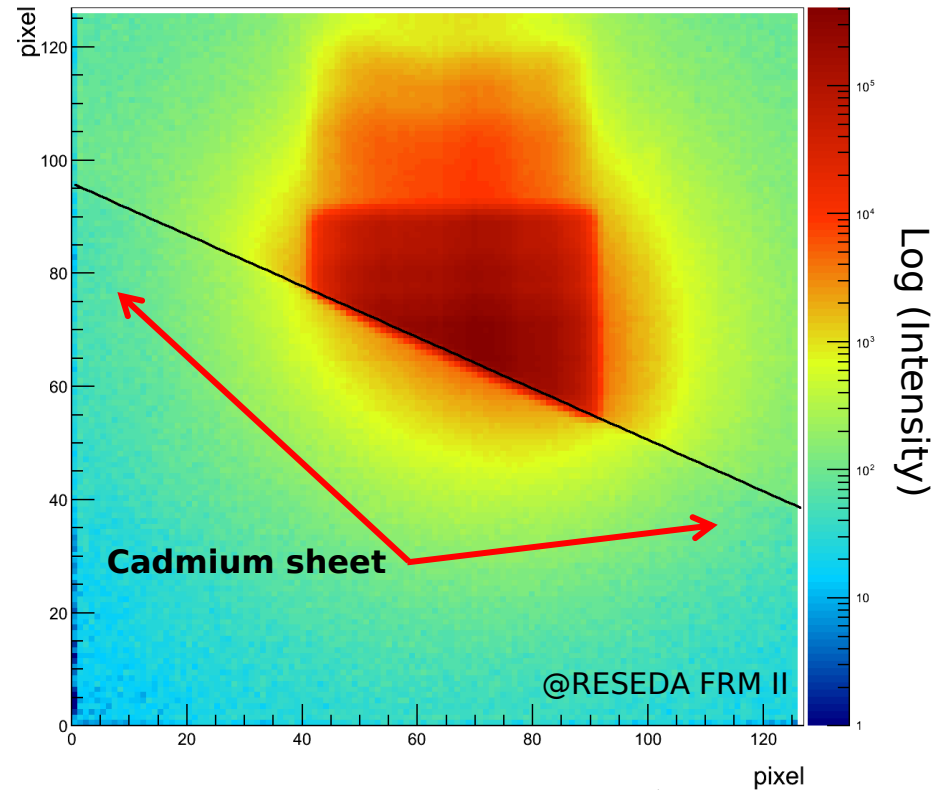

||| CASCADE  
Spin Echo

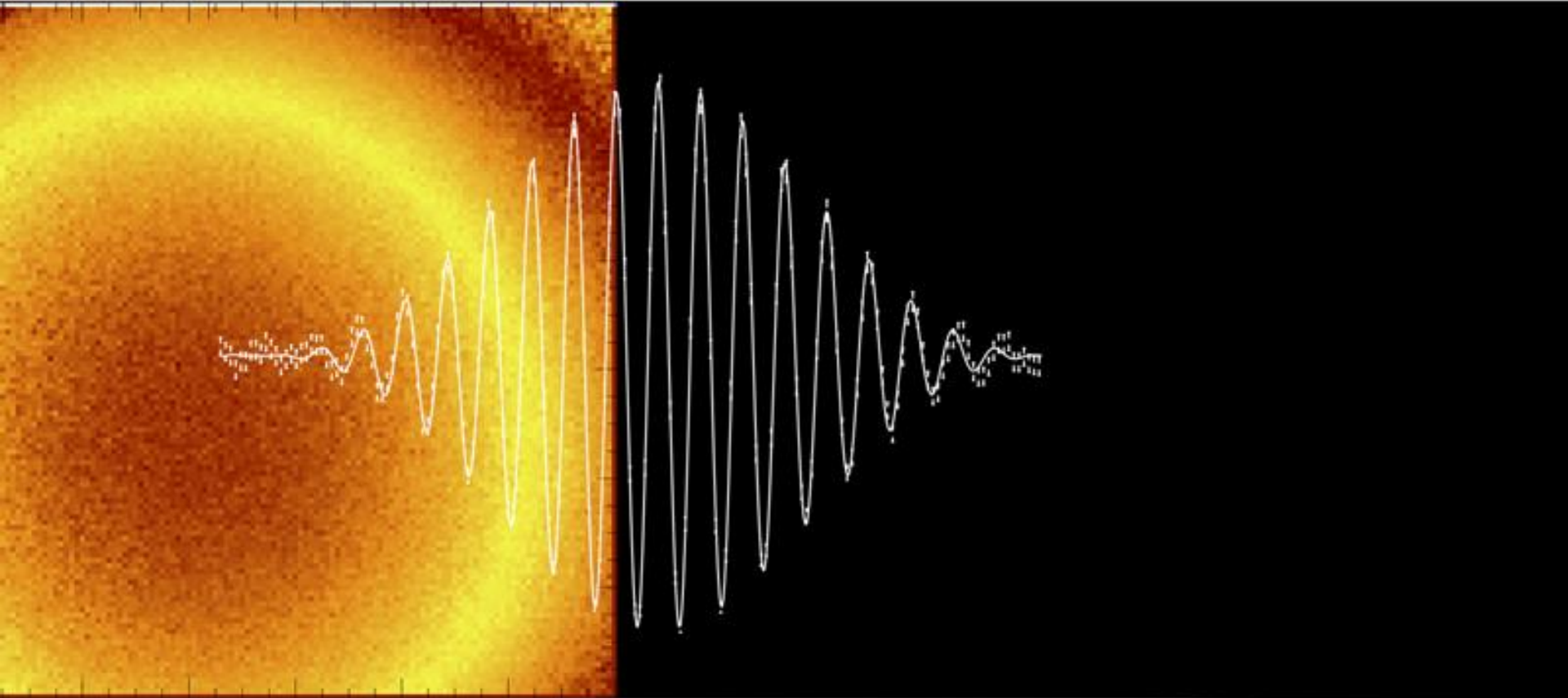

# Spin Echo - MIEZE

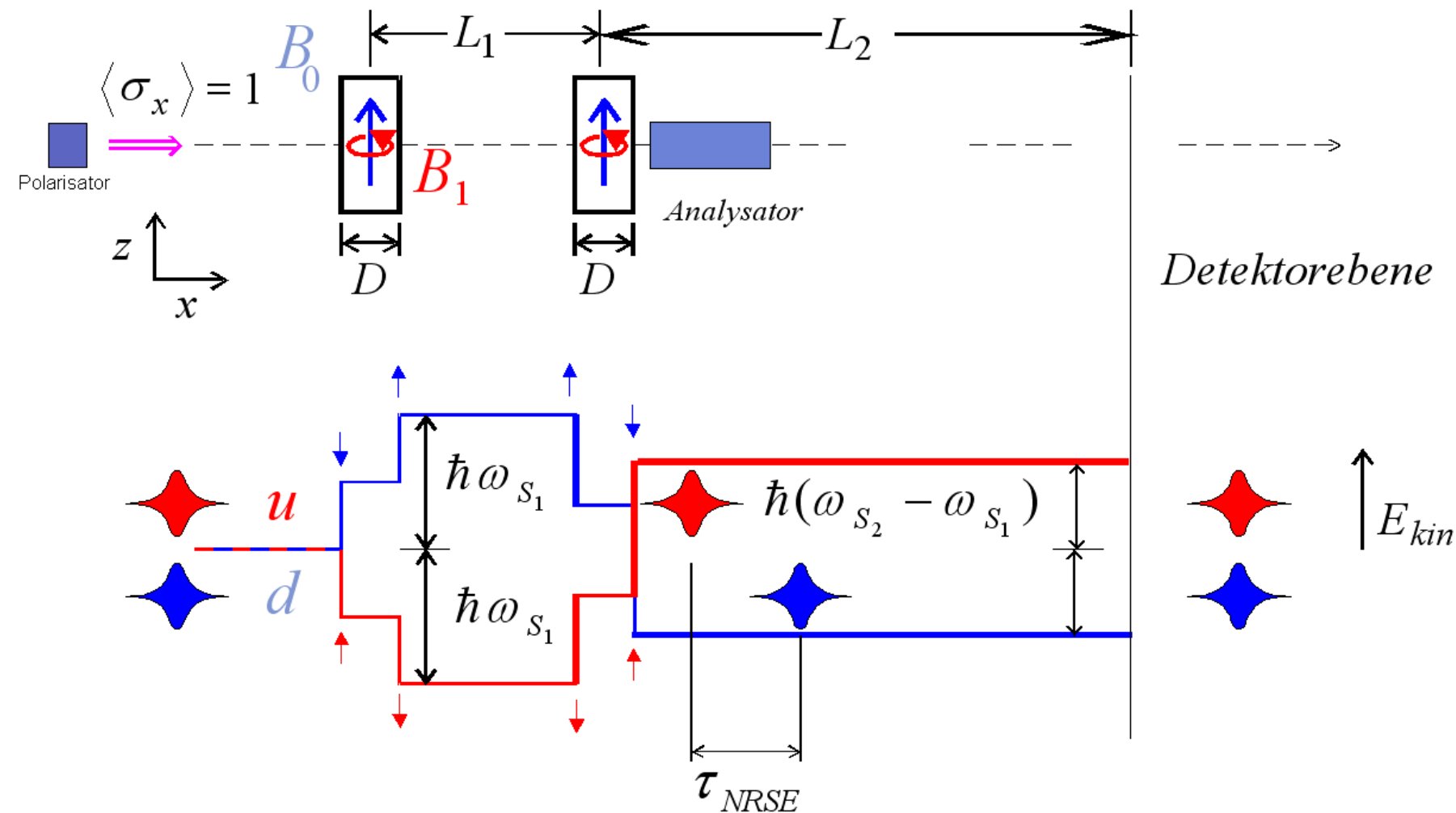

# Spin Echo - MIEZE

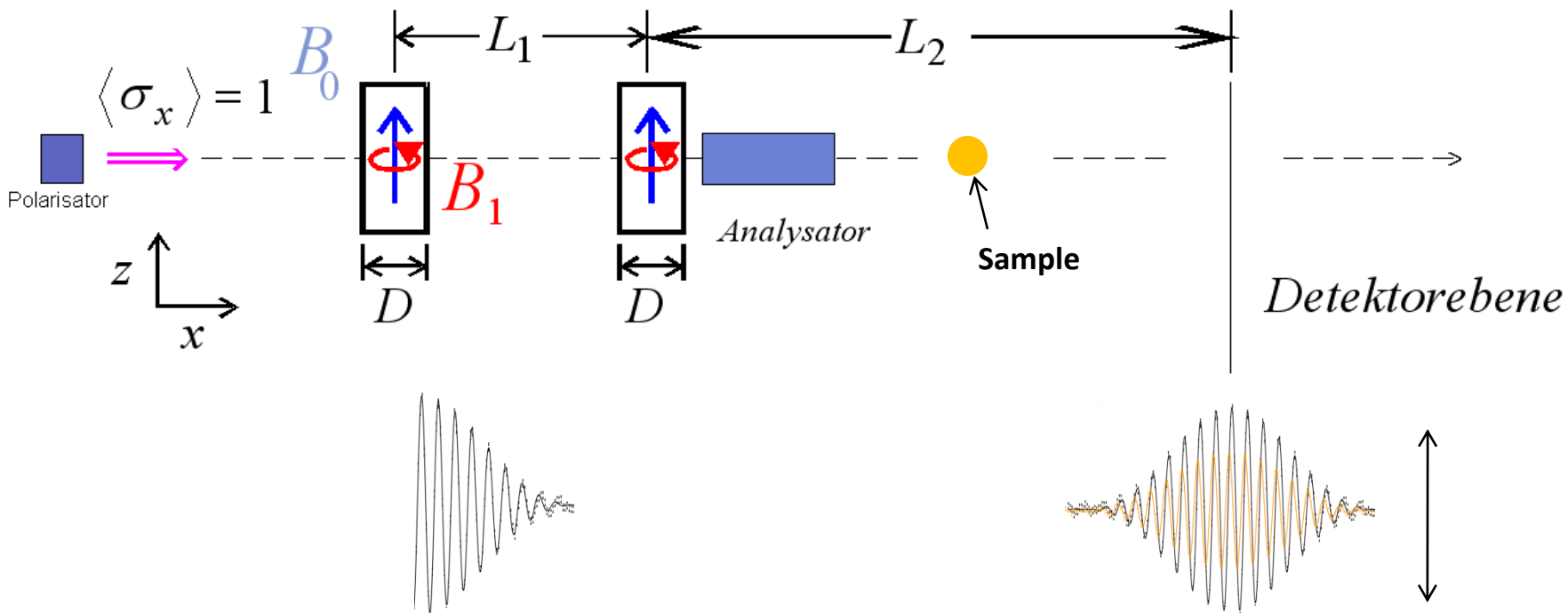

# Spin Echo Measurements

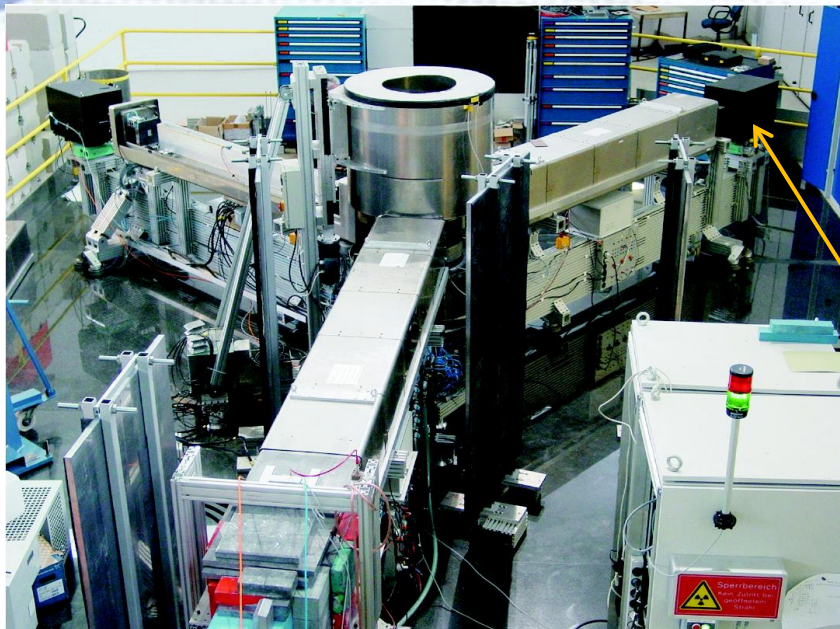

RESEDA, FRMII: spectrometer arms  
3 - 15 Å @ 11% FWHM

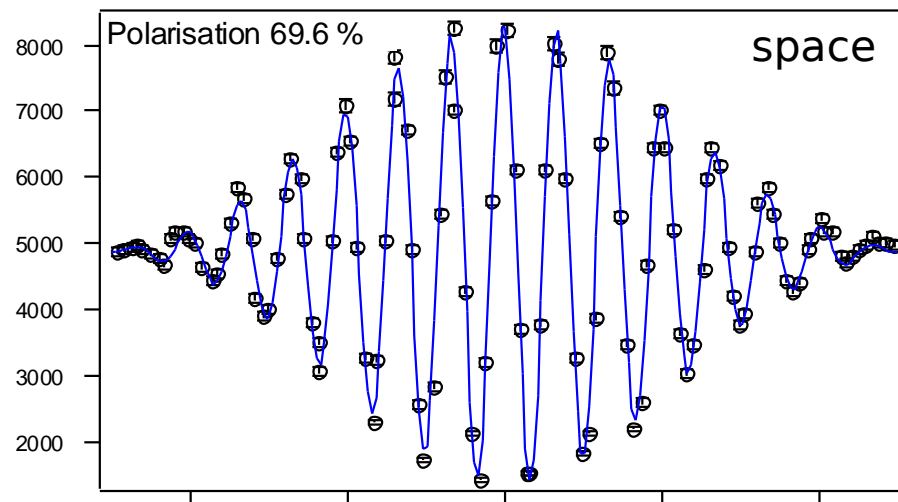

# Spin Echo Measurements

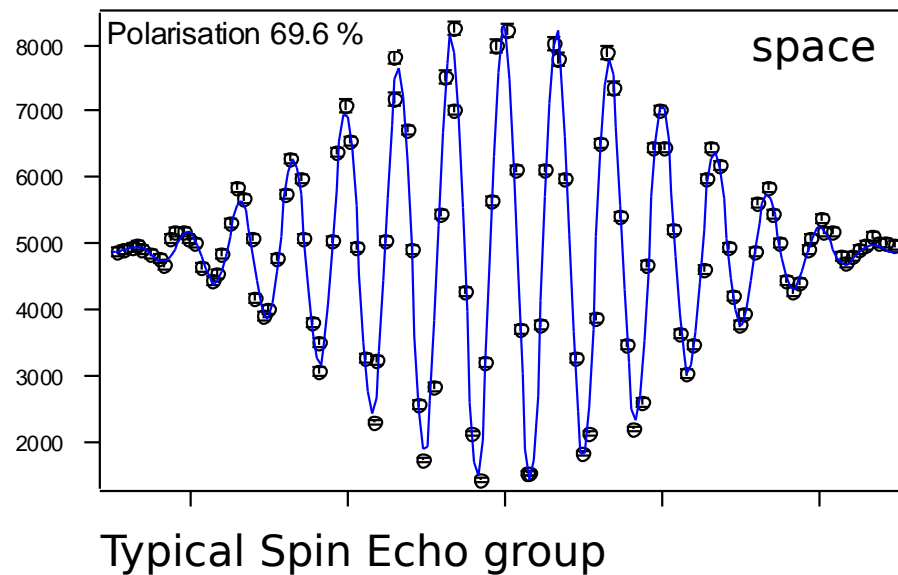
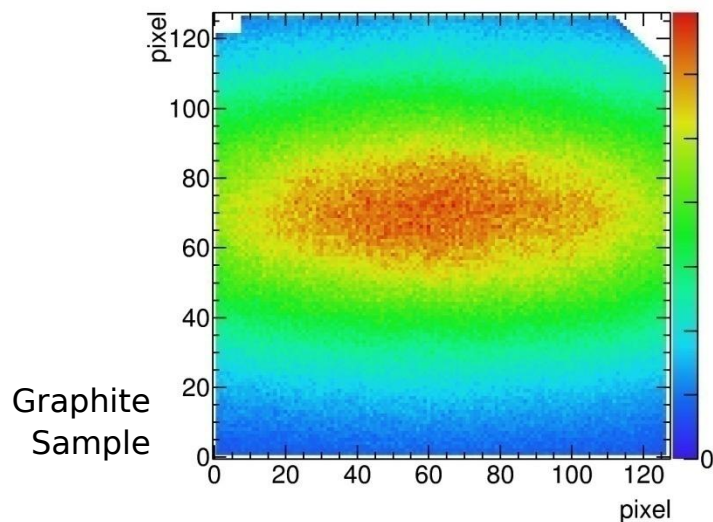

# Spin Echo Measurements

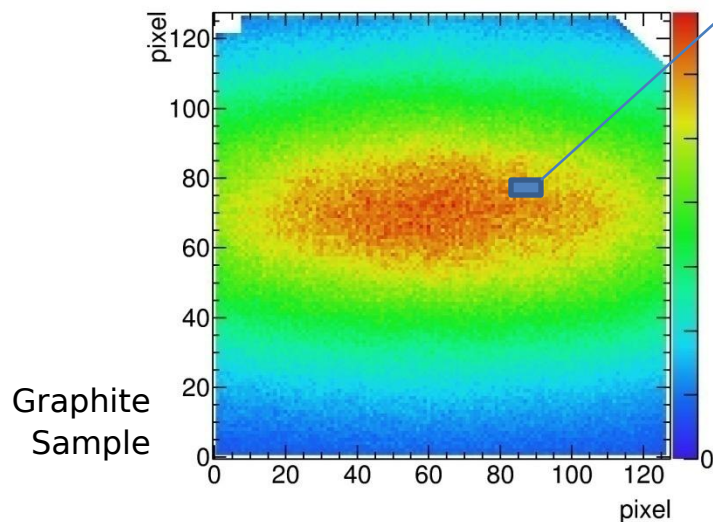

100 kHz x16

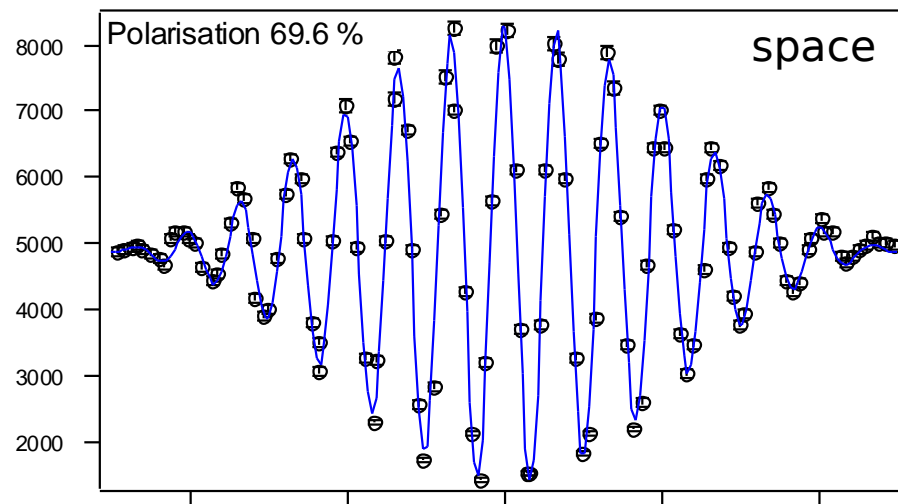
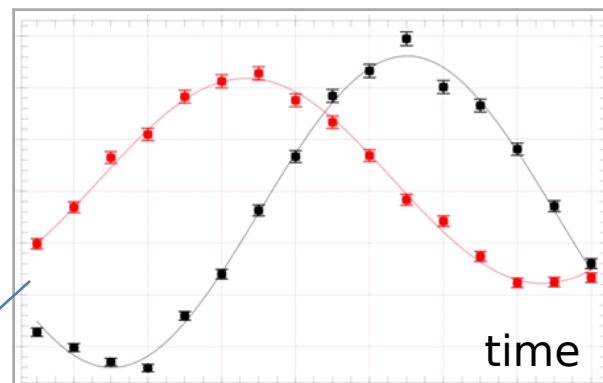

Typical Spin Echo group

# Spin Echo Measurements

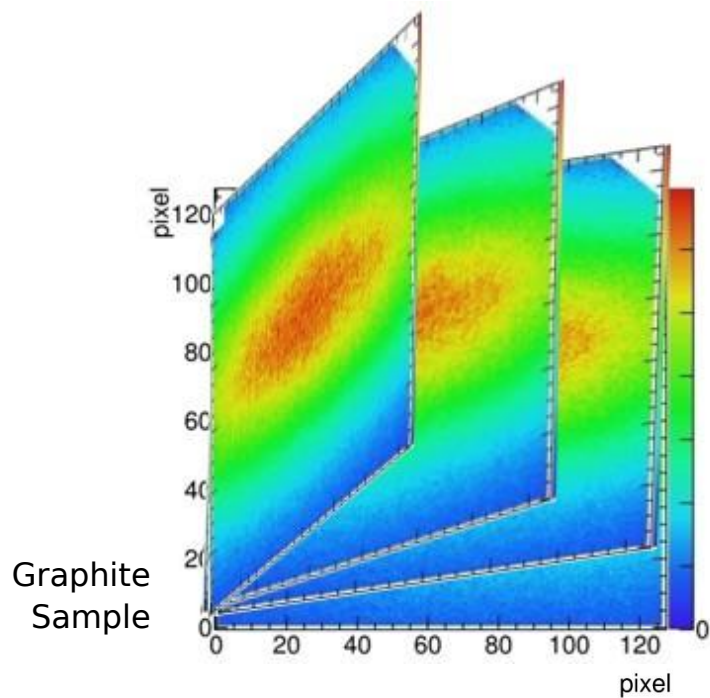

100 kHz x16

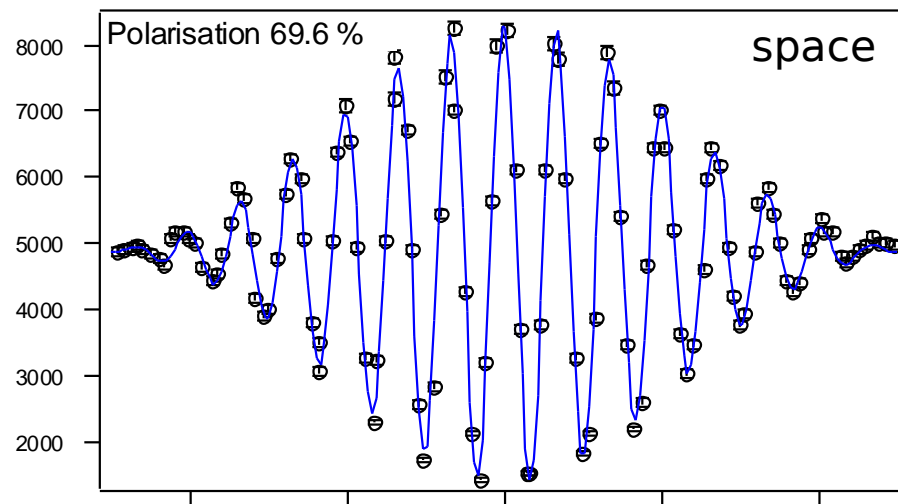
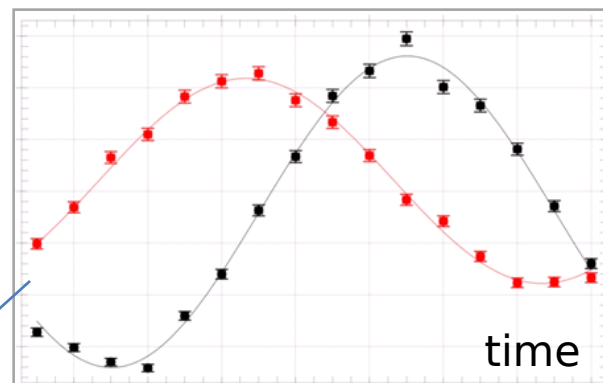

Typical Spin Echo group



# Spin Echo Measurements

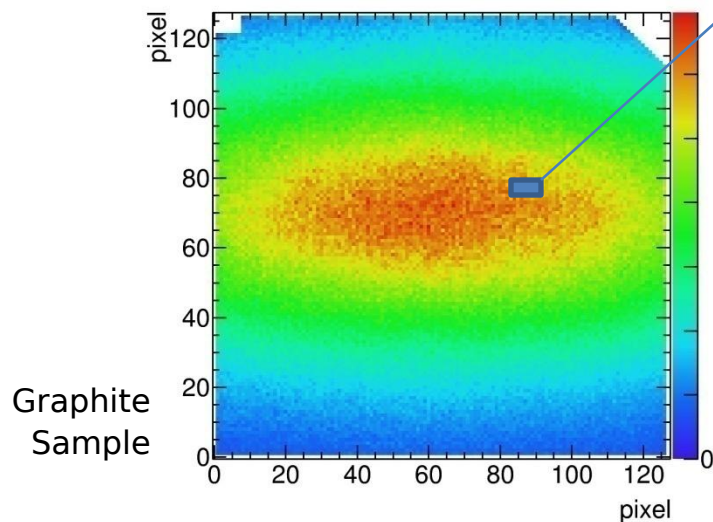

100 kHz x16

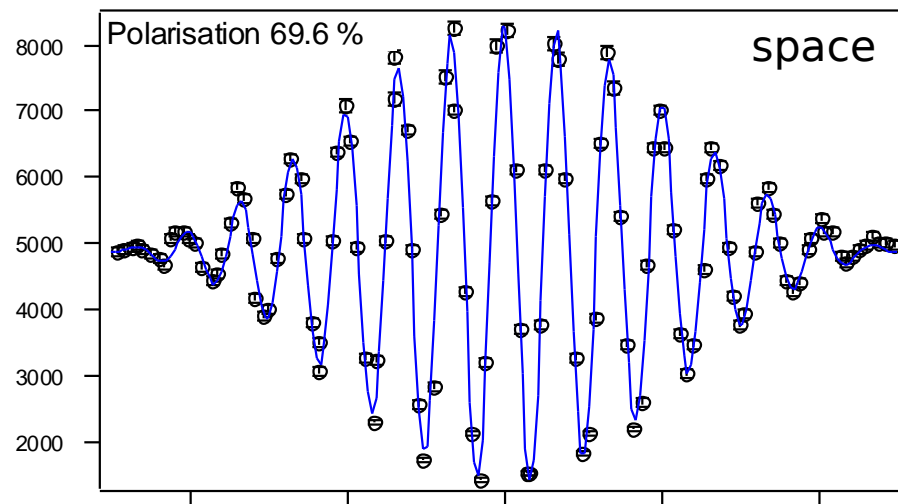
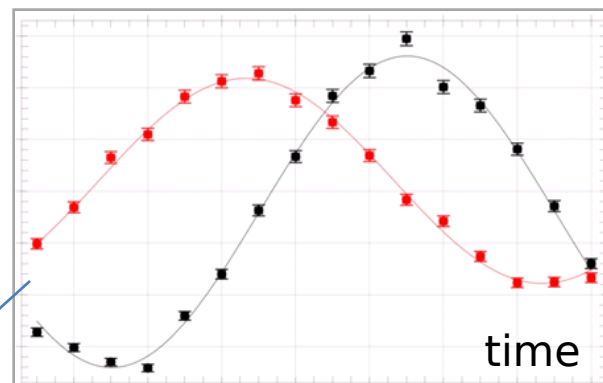

Typical Spin Echo group

# Spin Echo Measurements

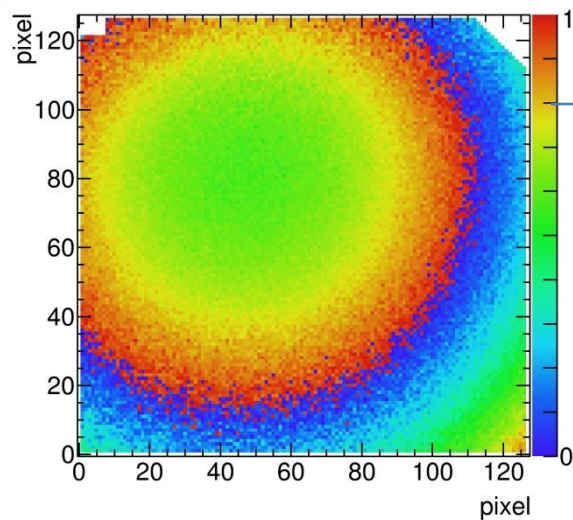

100 kHz x16

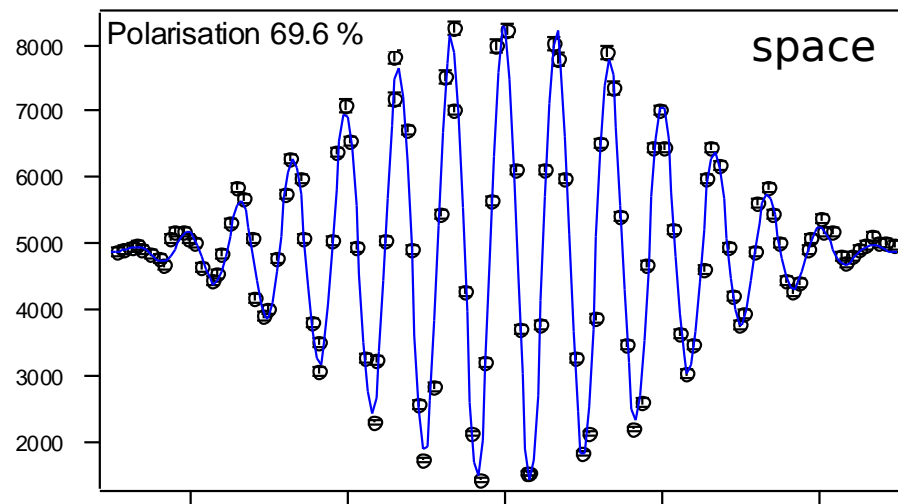
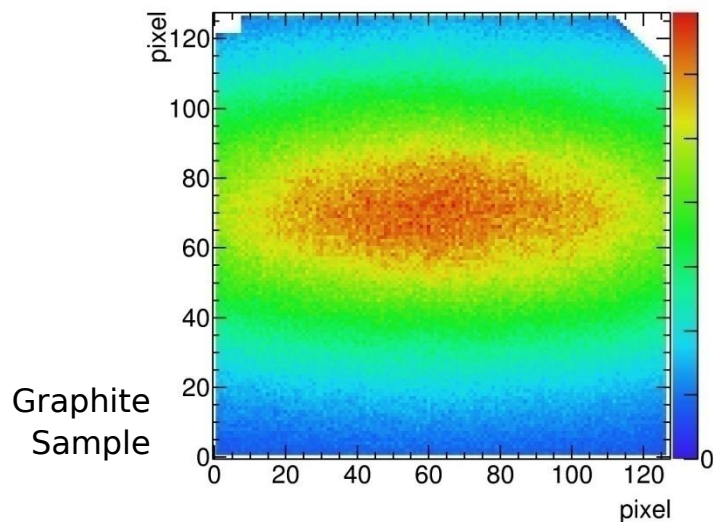
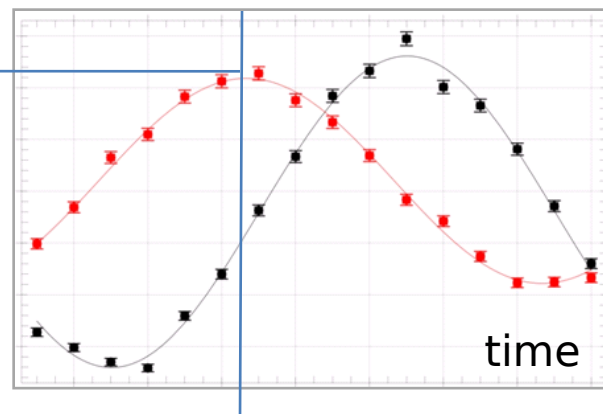

Typical Spin Echo group

# Spin Echo Measurements

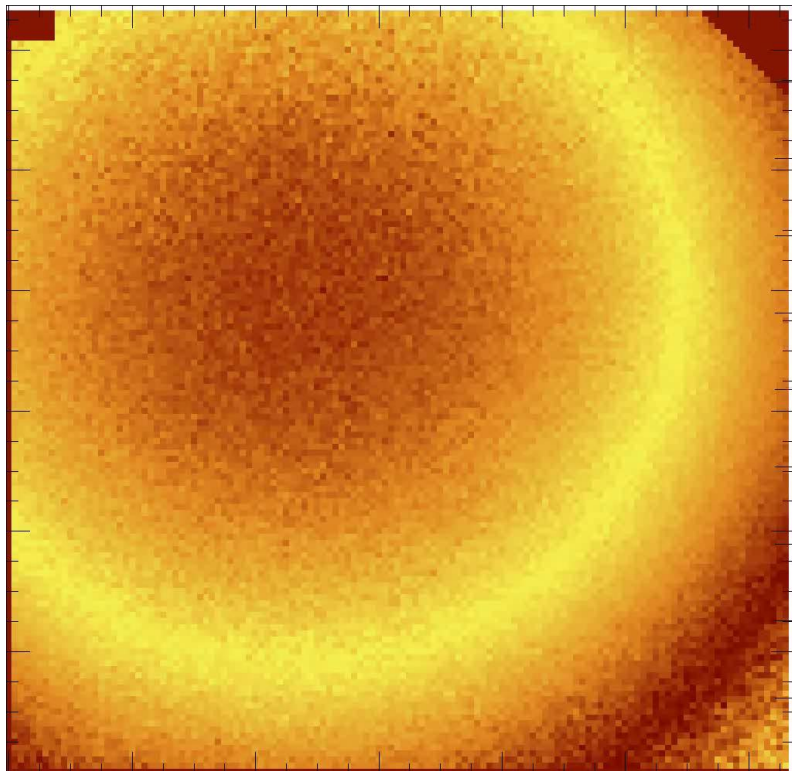

Phase View

100 kHz x16

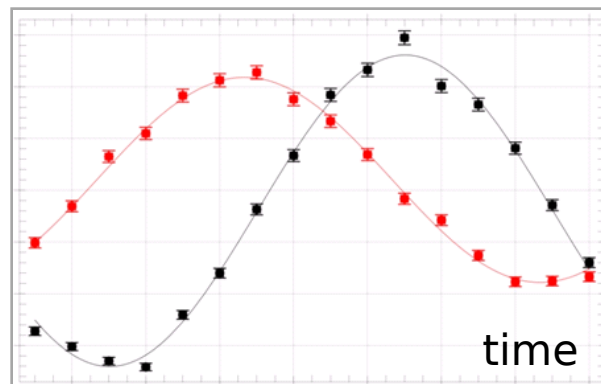

# Spin Echo Measurements

100 kHz x16

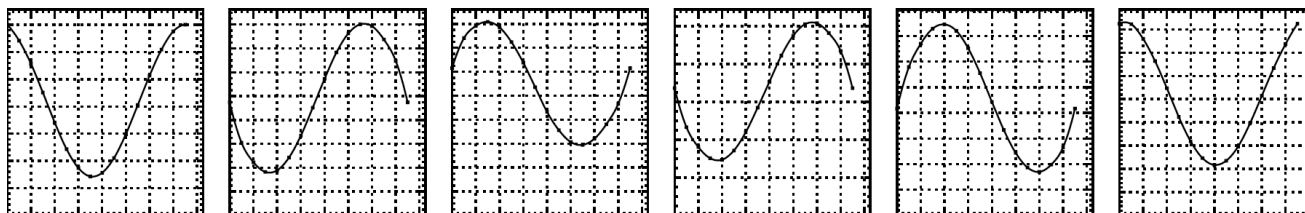
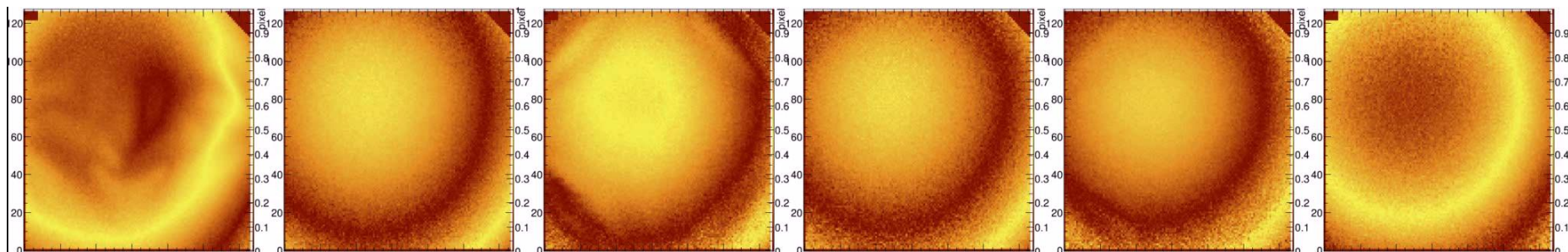
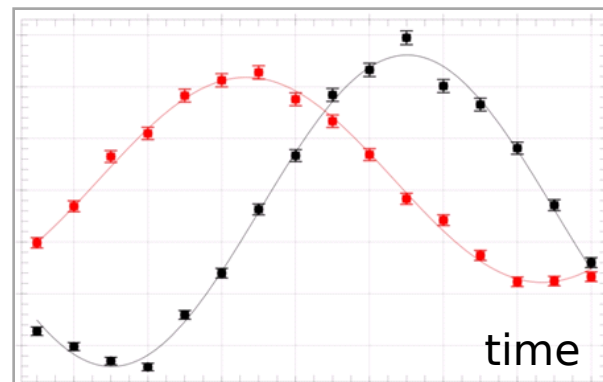

# Spin Echo Measurements

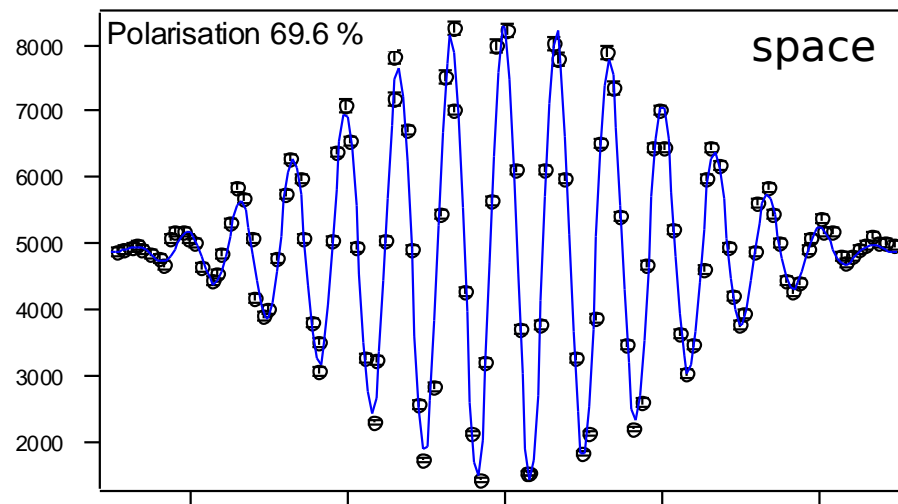
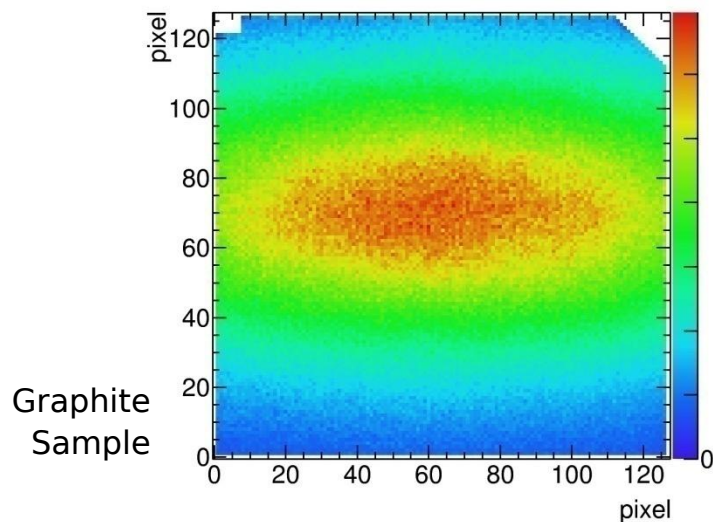
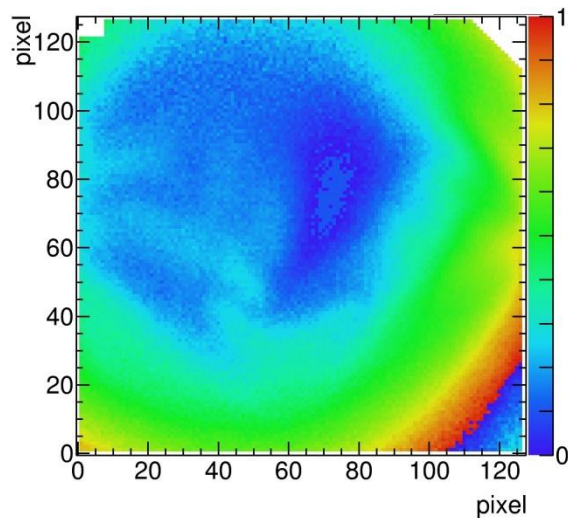

Typical Spin Echo group

# Spin Echo Measurements

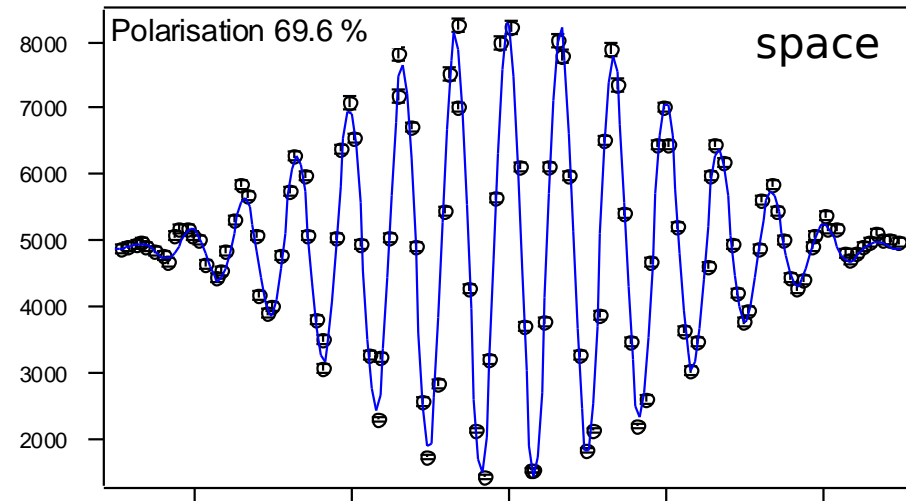
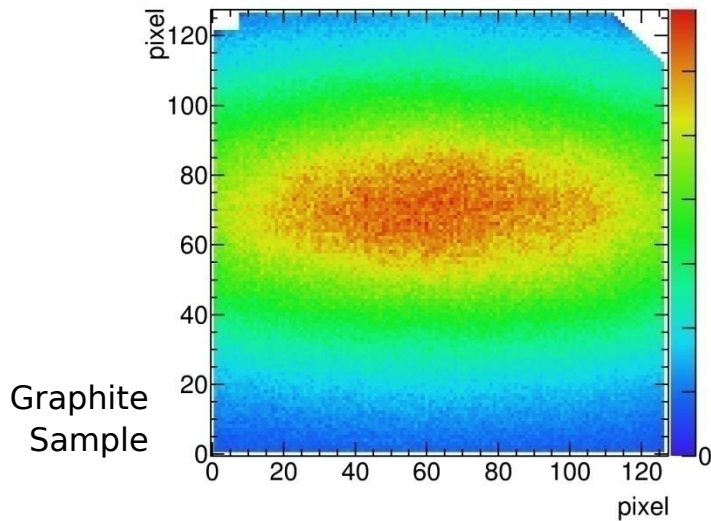
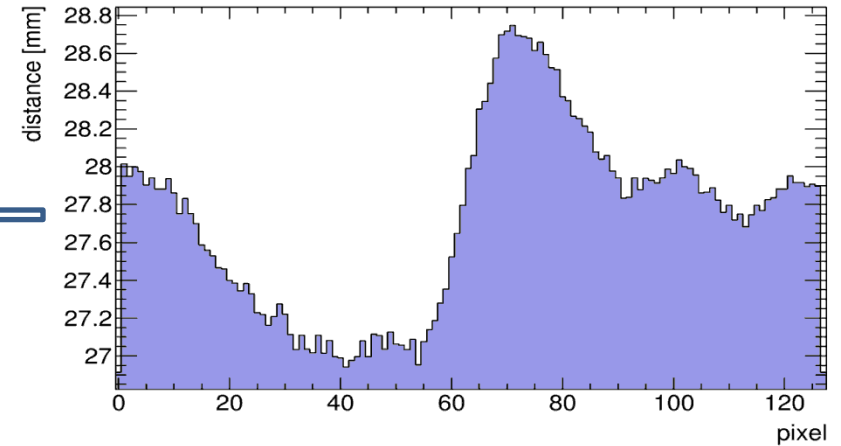
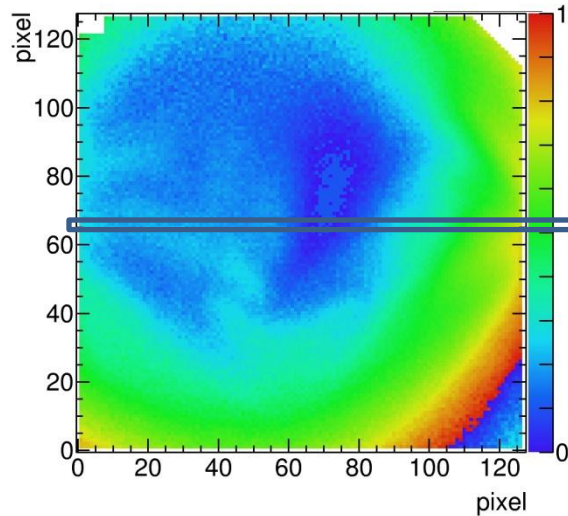

Typical Spin Echo group

# ||| BASTARD & BODELAIRE



# ▶ To New Shores

## CASCADE

Uni Heidelberg

Technology available in 2000

GEM

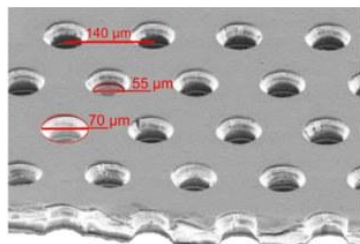

CiPix  
Multichannel  
ASIC

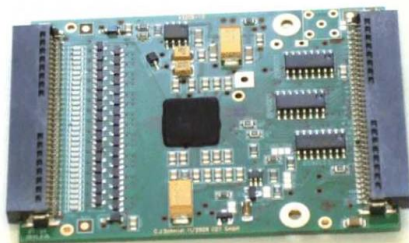



# ▶ To New Shores

## CASCADE Uni Heidelberg

Technology available in 2000

GEM

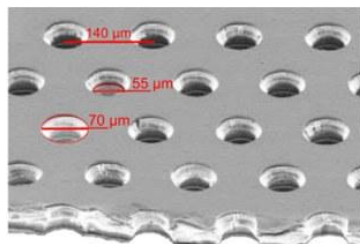

CiPix  
Multichannel  
ASIC

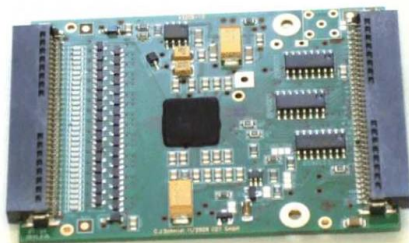

## New Project Uni Bonn

Technology available in 2017

TPC

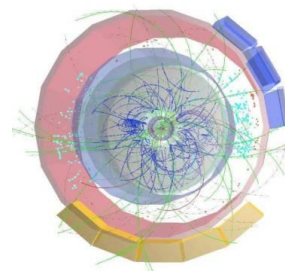

TimePix

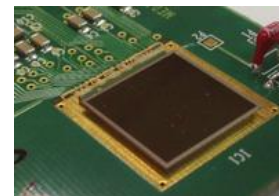

VMM ASIC

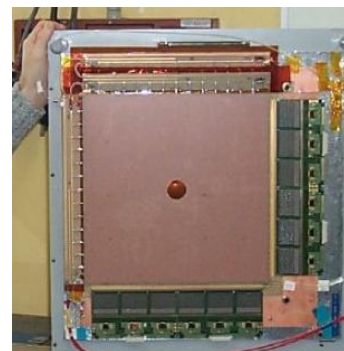

# To New Shores

**BODELAIRE**  
High Resolution

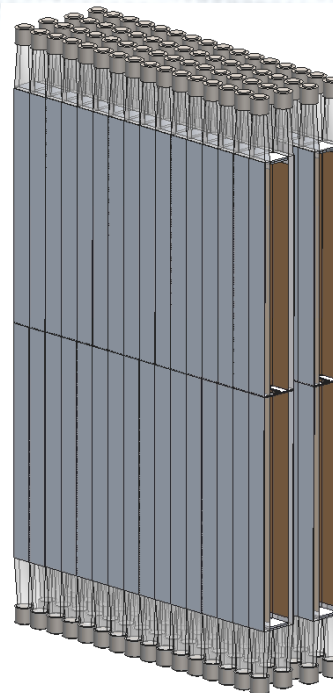

**BASTARD**  
High Rate

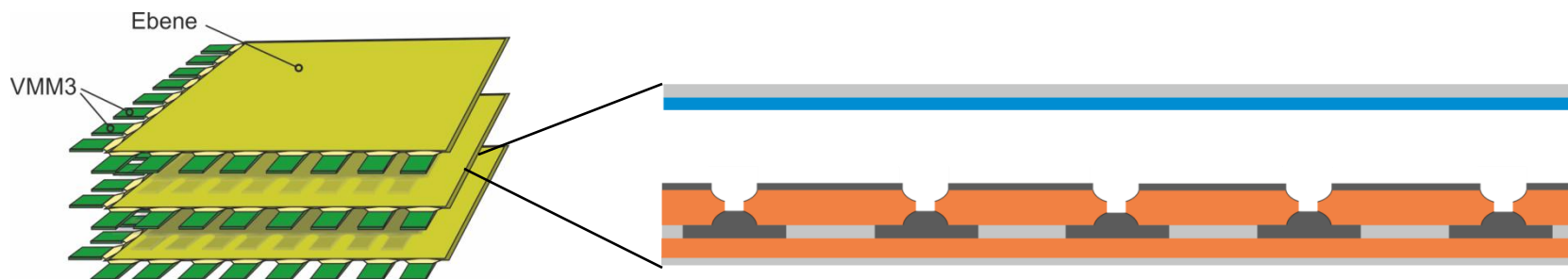

# The BASTARD System

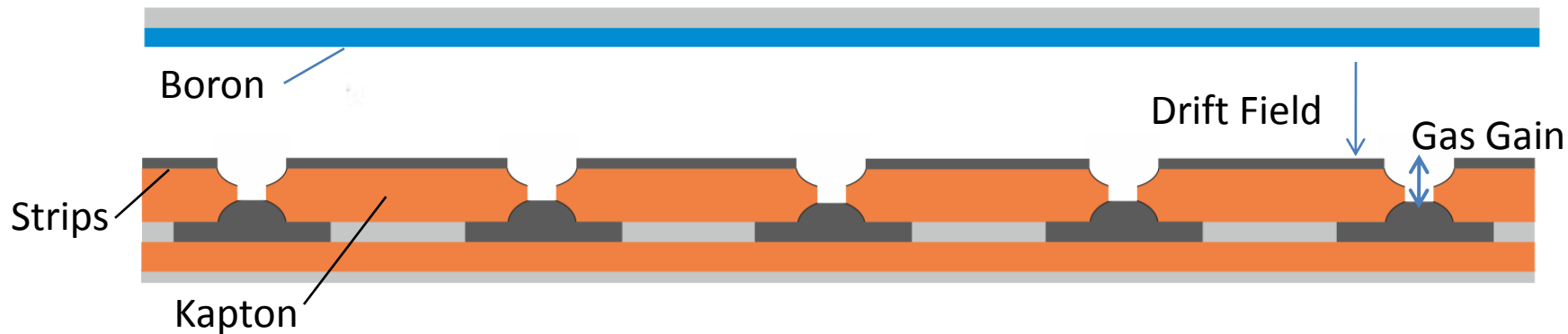

# The BASTARD System

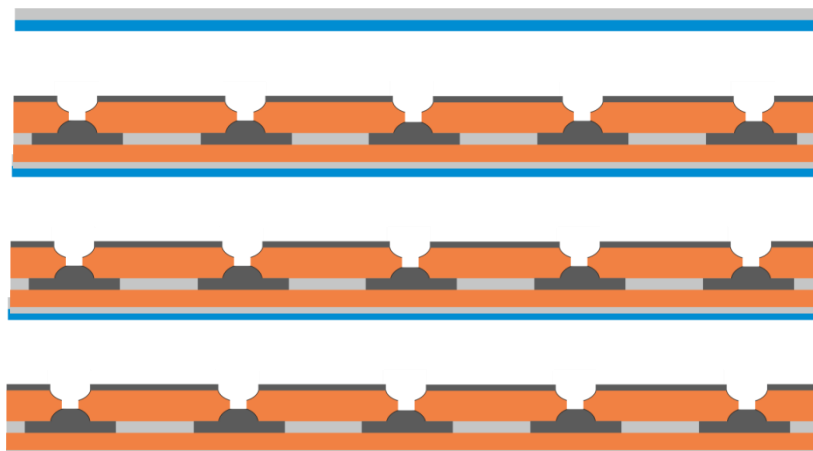
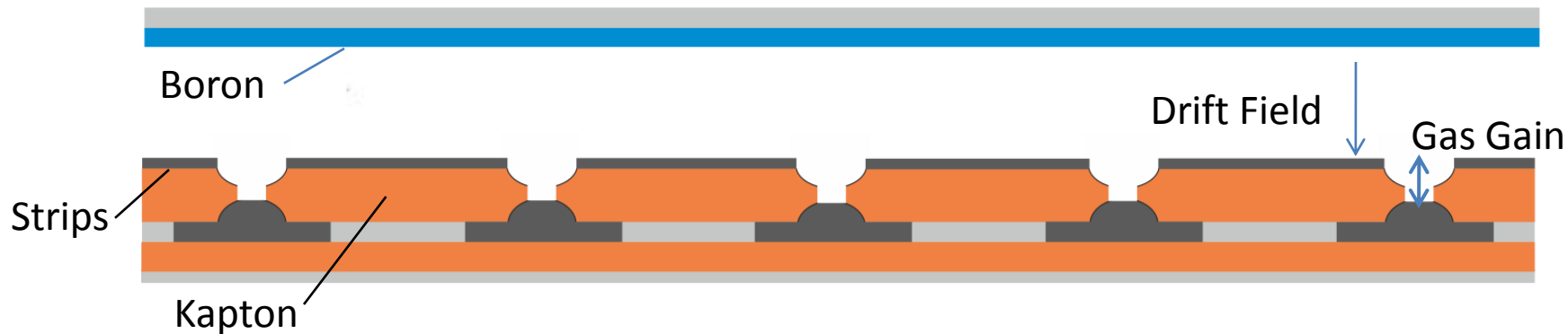

# The BASTARD System

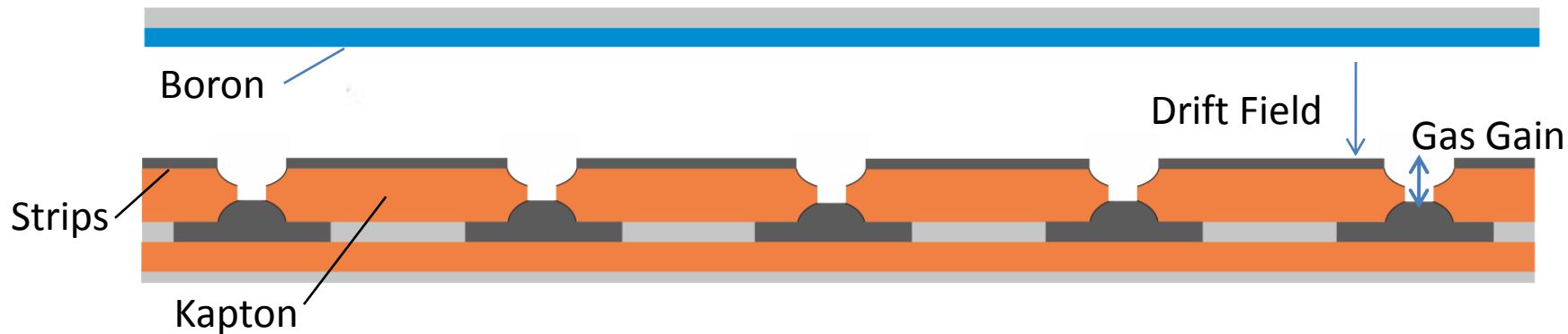

nXYter  
Prototype:

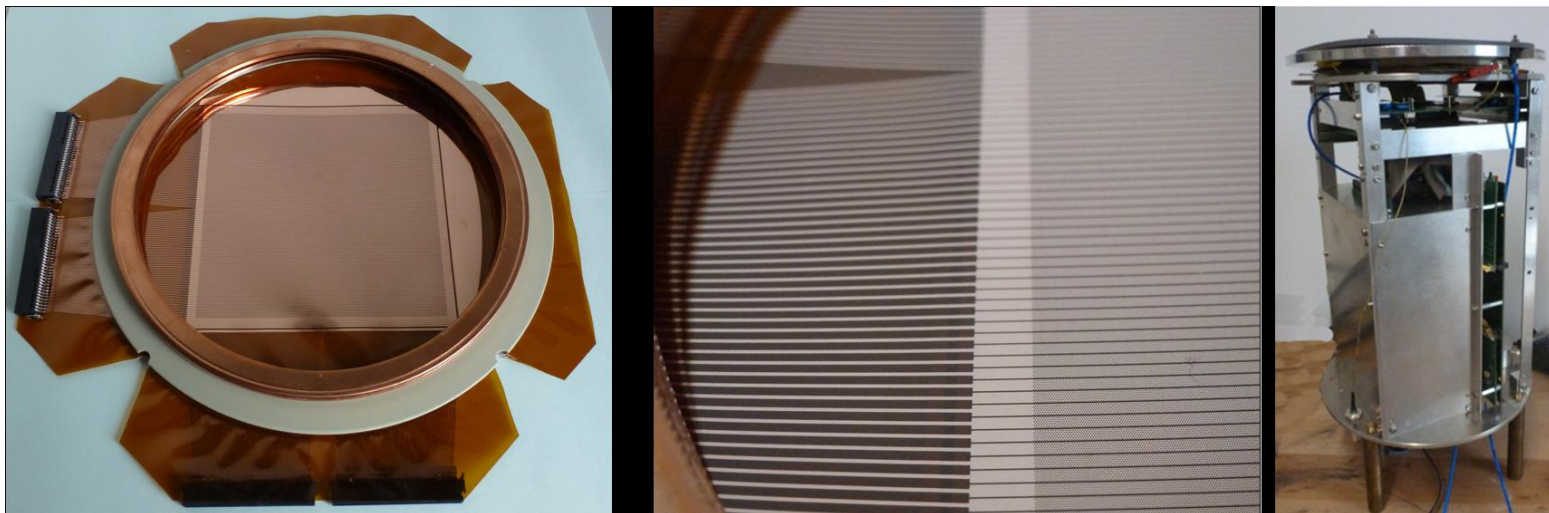

M. Liebig  
Uni HD  
2015

# The BASTARD System

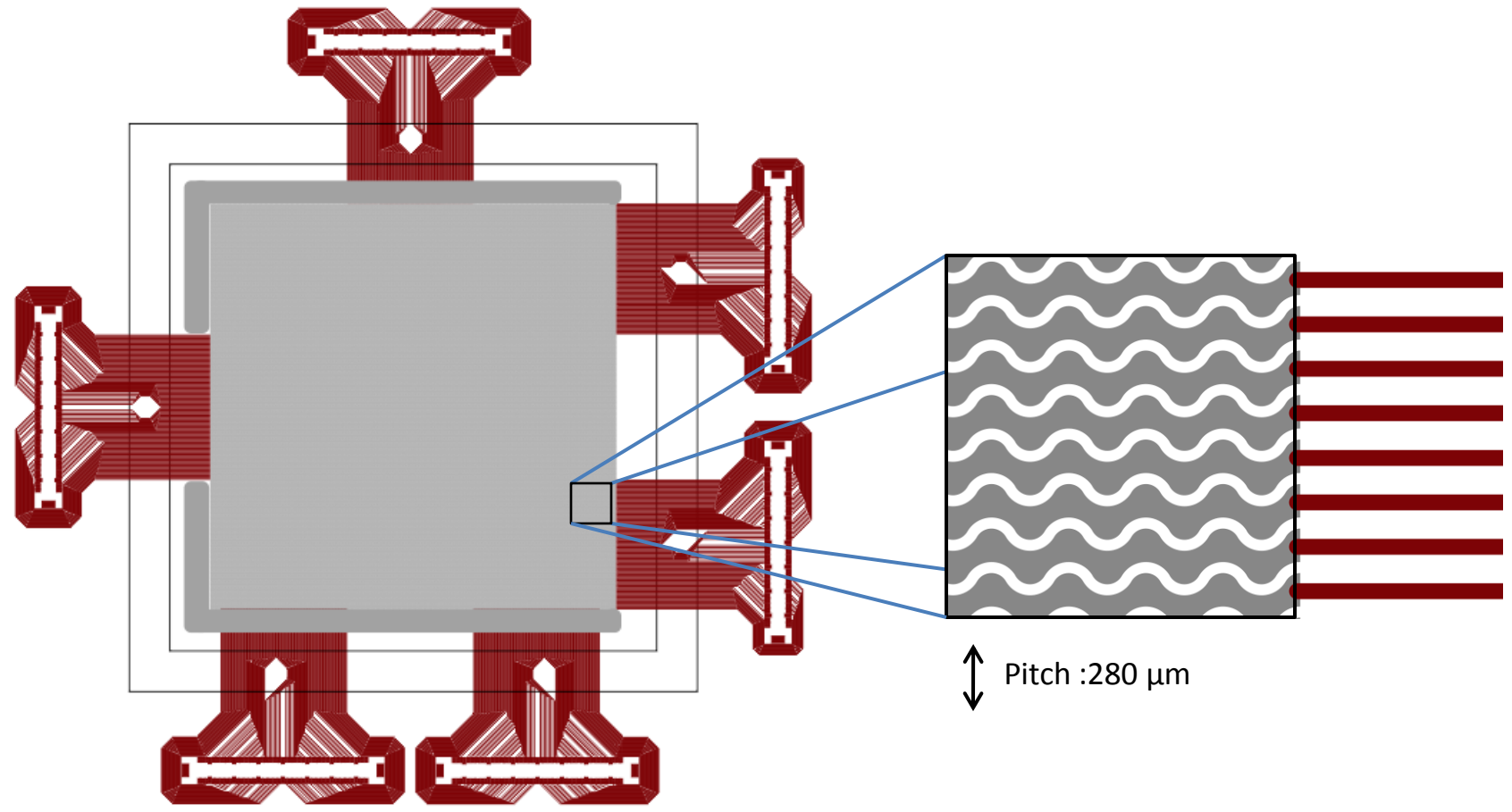

10 cm x 10 cm

Pitch : 280 μm

# The BASTARD System

VMM1  
2011/12

VMM2  
2013/14

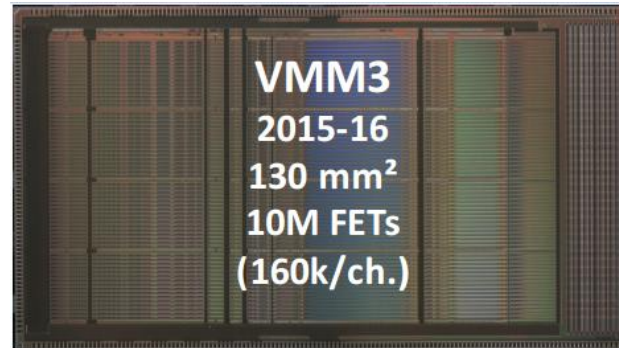

- 4 MHz/ch
- 10bit ADC
- self triggered
- 400 e<sup>-</sup> noise
- 1 ns time resolution

[1]

140 pin HRS connector FX10A-140P14-SV1

RC coupling network 220pF/1M

Spark protection  
DSILC6-4P6

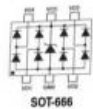

Spartan FPGA

MMCX GND and neighborhood connector

Master HDMI

2x globtopped VMM3 ASICs

IPL1 3 pin power connector

Slave HDMI

[2]

Flash chip

[1] G. Iakovidis, RD51 MiniWeek CERN, Feb. 2017

[2] H. Muller, RD51 SRS Status December 2016, CERN



# Summary & Outlook

**Markus Köhli**

Physikalisches Institut (LCTPC)

Rheinische  
Friedrich-Wilhelms-Universität  
Bonn

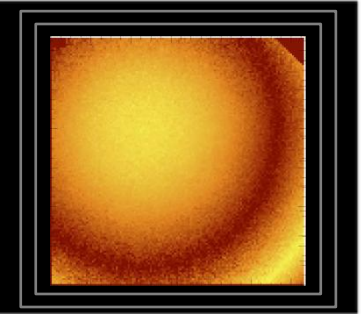



# Summary & Outlook

**Markus Köhli**

Physikalisches Institut (LCTPC)

Rheinische  
Friedrich-Wilhelms-Universität  
Bonn

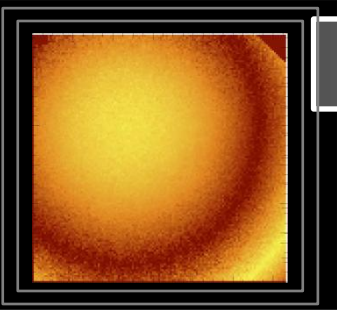

What can  $^{10}\text{B}$  based detectors offer?

# Summary & Outlook

**Markus Köhli**

Physikalisches Institut (LCTPC)

Rheinische  
Friedrich-Wilhelms-Universität  
Bonn



What can  $^{10}\text{B}$  based detectors offer?

high rate,  
spatially and time resolved detectors  
(for Imaging/Spin Echo applications)

# Summary & Outlook

**Markus Köhli**

Physikalisches Institut (LCTPC)

Rheinische  
Friedrich-Wilhelms-Universität  
Bonn



What can  $^{10}\text{B}$  based detectors offer?

high rate,  
spatially and time resolved detectors  
(for Imaging/Spin Echo applications)

BASTARD (high rate, good resolution)

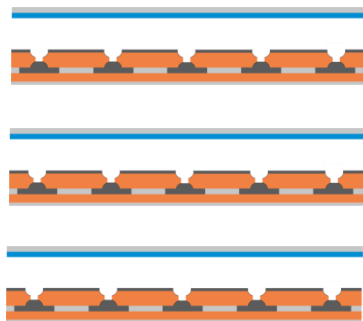

# Summary & Outlook

**Markus Köhli**

Physikalisches Institut (LCTPC)

Rheinische  
Friedrich-Wilhelms-Universität  
Bonn



What can  $^{10}\text{B}$  based detectors offer?

high rate,  
spatially and time resolved detectors  
(for Imaging/Spin Echo applications)

BASTARD (high rate, good resolution)

BODELAIRE (high resolution)

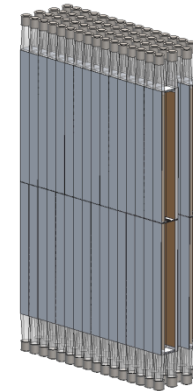
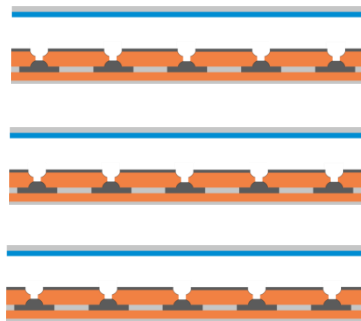

# Summary & Outlook

**Markus Köhli**

Physikalisches Institut (LCTPC)

Rheinische  
Friedrich-Wilhelms-Universität  
Bonn

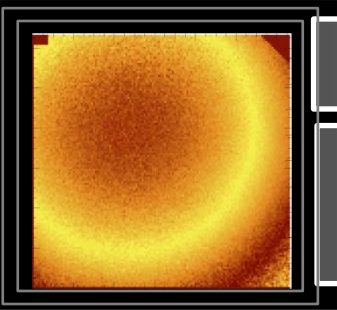

What can  $^{10}\text{B}$  based detectors offer?

high rate,  
spatially and time resolved detectors  
(for Imaging/Spin Echo applications)

BASTARD (high rate, good resolution)

BODELAIRE (high resolution)

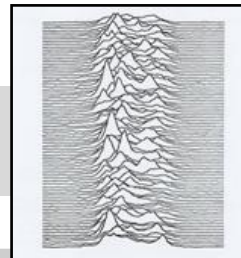
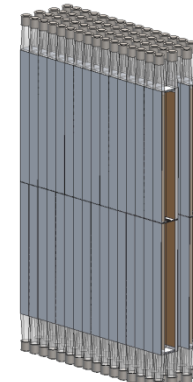
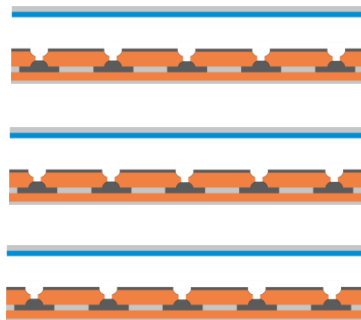

to be continued  
T. Wagner & F. Schmidt

